



## RESEARCH DESIGN & STANDARDS ORGANIZATION

### Manak Nagar, Lucknow-226011

### Indian Railway Standard Specification for Fusion Welding of Rails By Alumino – Thermic Process Serial No. IRST-19-2021

#### Amendment History:

S.No.	Amendment Date	Version	Reasons for Amendment
1	1961	1.0	First issue of specification
2	1965	2.0	-
3	1984	3.0	-
4	1994	4.0	-
5	2012	5.0	Technological improvements in the AT Welding process and additional provisions for implementation of upgraded AT welding technology with superior weld performance on Indian Railways
6	2020	6.0	Inclusion of AT welding technique for R260 and 1175 HT grade Rail.
7	2021	7.0	Para 3.4.1 (i) modified and bag colour code for combination grade rails added. Para 4.4.2 modified and foot note under table 1B is also modified. Foot note under table-2 in para 4.4.3.1 is modified. Last paragraph in para 4.5 added. Para 12.5.1 and para 12.5.1 (i) modified. New sub-para v) added under para 13.1. Under para 13.3 sub-para iv) is modified and new sub-para vi) added. Para 14.0 Field trial is modified and Annexure-5, 5A, 5B & 5C added accordingly. Foot note under table-4 in para 15.1 is removed.

			Printed:
Prepared By: SSE/Track	Checked By: DD/Track/W	Issued By: DST-5	Page 1 of 63

**CONTENTS**

Para. No.	Description	Page No.
1	Introduction	4
2	Scope	5
	<b>Part A : Technical Requirements for Thermit Portions</b>	<b>6</b>
3	Supply of the Portions	6
4	Acceptance Test	8
5	Disposal of Rejected Batch	16
6	Acceptance	16
7	Disposal of Rejected Portions	16
8	Testing Facilities	16
9	Inspection of Premises and Records	16
10	<b>Part B: Approval of Portion Manufacturers</b>	<b>17</b>
11	Definitions	17
12	Procedure for Approval of Portion Manufacturers	18
13	Fatigue Test	20
14	Field Trials	21
15	Requirements for Up gradation of Approved Welding Techniques	23
16	<b>Part-C-Procedure for Approval of AT Welding Supervisors and Welders</b>	<b>24</b>
	<b>Part D: Acceptance Test of Joints welded at site</b>	<b>27</b>
17	Execution of Welds at Site	27
18	Acceptance Tests	28
19	Guarantee	31
20	Marking	32
21	Withdrawal of Approval of Portion Manufacturer/Welding Supervisor /Welder from Approved List	33
22	<b>Part-E: Approval of Portion Manufacturers for Up graded AT Welding Technology</b>	<b>34</b>

ALOK NATH GUPTA <small>Digitally signed by ALOK NATH GUPTA Date: 2022.02.05 13:44:26 +05'30'</small>	Jaina Ram Meena <small>digitally signed by jaina ram meena Date: 2022.02.05 13:23:57 +05'30'</small>	SACHIN VERMA <small>Digitally signed by SACHIN VERMA Date: 2022.02.06 18:01:44 +05'30'</small>	Printed:
Prepared By: SSE/Track	Checked By: DD/Track/W	Issued By: DST-5	Page 2 of 63

**LIST OF ANNEXURES**

<b>Annexure No.</b>	<b>Description</b>	<b>Page No.</b>
<b>1</b>	Procedure for Microscopic Examination of the Visible Heat Affected Zone of Welds	<b>39</b>
<b>2</b>	Specification of 3-Pieces Pre-Fabricated Mould Manufactured by A.T. Portion Manufacturers for use during A.T. Welding of Rails.	<b>40</b>
<b>3</b>	Specification of single shot crucible manufactured by A.T portion manufacturers for use during A.T welding of rails	<b>47</b>
<b>4</b>	Fatigue Test Arrangement for A.T welds.	<b>53</b>

**LIST OF FIGURES**

<b>Figure No</b>	<b>Description</b>	<b>Page No.</b>
<b>1</b>	Location for determination of hardness	<b>10</b>
<b>2</b>	Shape of fusion Zone on the etched longitudinal vertical section	<b>14</b>
<b>3</b>	Location of marking on non- gauge face of welds	<b>32</b>
<b>4</b>	Scheme for taking samples for microscopic examination	<b>39</b>
<b>5</b>	Arrangement of 3 Pieces PFM	<b>41</b>
<b>6</b>	Single Shot Crucible	<b>48</b>
<b>7</b>	Fatigue Test Arrangement	<b>53</b>
<b>8 (a)</b>	Tolerances for Vertical Misalignment of Welded Joint	<b>63</b>
<b>8 (b)</b>	Tolerances for Lateral Misalignment of Welded Joint	<b>63</b>
<b>8 (c)</b>	Tolerances for Finishing on Sides of Head of Welded Joint	<b>63</b>
<b>8 (d)</b>	Tolerances for Finishing Top Table Surface of Welded Joint	<b>63</b>

ALOK NATH GUPTA <small>Digitally signed by ALOK NATH GUPTA Date: 2022.02.05 13:44:26 +05'30'</small>	Jaina Ram Meena <small>digitally signed by jaina ram meena Date: 2022.02.05 13:29:57 +05'30'</small>	SACHIN VERMA <small>Digitally signed by SACHIN VERMA Date: 2022.02.06 18:01:44 +05'30'</small>	Printed:
Prepared By: SSE/Track	Checked By: DD/Track/W	Issued By: DST-5	Page 3 of 63

**INDIAN RAILWAY STANDARD SPECIFICATION FOR FUSION WELDING OF RAILS BY ALUMINO – THERMIC PROCESS Serial No. IRS T-19- 2021**

**FOREWORD**

This specification is issued under the fixed serial No. T-19. This was originally adopted in 1961 and was revised in 1965, 1984, 1994, 2012 and 2020. Since then, number of amendments have been made in this specification on account of technological improvements in the Alumino – thermic (AT) welding process. Besides this, R&D work was undertaken on upgraded AT welding technology. This sixth revision includes current technological improvements in the AT Welding process and inclusion of AT welding techniques for R260 and 1175 HT grade Rail.

AT Welding technique, this was approved as per IRS T-19:2020 shall remain valid. However, “**TECHNICAL REQUIREMENTS FOR THERMIT PORTIONS**” as specified in Part A and “**ACCEPTANCE TEST OF JOINTS WELDED AT SITE**” as specified in Part C of this specification IRS T-19:2021 shall be applicable.

**1.0 INTRODUCTION**

- 1.1 The soundness of the welds produced by alumino – thermic process depends on the quality of (a) Alumino - thermic mixture hereinafter referred to as the ‘MIXTURE’ and (b) the technical control exercised during the preparation for and the execution of the welding by this process.
- 1.2 The quantity of the ‘MIXTURE’ required for welding one rail joint shall be called a ‘portion’.
- 1.3 A batch shall consist of a number of ‘portions’ manufactured from similarly and simultaneously treated raw materials.
- 1.4 “Portions” manufactured by agencies approved by RDSO and accepted by nominated inspecting authority shall only be used.
- 1.5 Except for welds executed for laboratory evaluation and acceptance tests, which are done by RDSO, all other welds shall be executed under the supervision of personnel possessing valid competency certificate from Thermit Portion Plant, Northern Railway, Charbagh, Lucknow or Thermit Welding Centre (TWC), South-Central Railway, Vijayawada.
- 1.6 No changes in weld design, range of weld metal chemistry, its acceptance tests and the methods of welding shall be made without the consent of the approving authority. Approving Authority shall mean Director General, Research Design & Standards Organization (Ministry of Railways), Manak Nagar, Lucknow – 226011 or his representative.

ALOK NATH GUPTA <small>Digitally signed by ALOK NATH GUPTA Date: 2022.02.05 13:44:36 +05'30'</small>	Jaina Ram Meena <small>digitally signed by jaina ram meena Date: 2022.02.05 13:29:07 +05'30'</small>	SACHIN VERMA <small>Digitally signed by SACHIN VERMA Date: 2022.02.06 18:01:44 +05'30'</small>	Printed:
Prepared By: SSE/Track	Checked By: DD/Track/W	Issued By: DST-5	Page 4 of 63

1.7 The numerical values may be rounded off as per IS: 2.

**2.0 SCOPE**

2.1 This specification is for AT Welding of rails conforming to IRS Specification for Flat bottom rails i.e. IRS T-12.

2.2 This Indian Railway Standard covers: -

- (i) Technical requirements for thermit portions and welded joints including various acceptance tests.
- (ii) Procedure for approval of Alumino-thermic “portion manufacturers”
- (iii) Procedure for approval of A.T. Welding Supervisors, Welders and contracting firms.
- (iv) Acceptance tests for in-situ and cess Alumino -thermic joints.
- (v) Procedure for approval of Alumino- thermic portion manufacturers with upgraded Alumino- thermic welding technology.

2.3 Reference Documents: This standard refers to the following Indian Standards of the Bureau of Indian Standards. These shall be available at the manufacturers’ works for reference.

- (i) IS:2 Rules for rounding off numerical values
- (ii) IS:187 Cotton long cloth
- (iii) IS:9738 Polyethylene bags for general purposes
- (iv) IS:2500 (Pt. I) Sampling inspection tables:  
Part I inspection by attributes and by count of defects.
- (v) IS:1500 Method for Brinell hardness test for metallic materials.

2.4 All the provisions contained in RDSO’s ISO procedures laid down in Document No. QO-D-8.1-11 dated 01.07.2020, Version No: 1.3, (titled “Vendor-Changes in approved status”) and subsequent versions/amendments thereof, shall be binding and applicable on the successful vendor/vendors in the contracts floated by Railways to maintain quality of products supplied to Railways.

2.5 Nominal Gap and its tolerance

S.N	Nominal Gap (in mm)	Tolerance (in mm)
1	25	±1
2	50	±1
3	75	±1

ISO 9001:2015	Document No:IRST-19-2021	Version No: 7	Effective Date: 01.02.2022
Document Title: Indian Railway Standard Specification for Fusion Welding of Rails By Alumino – Thermic Process Serial No. IRST-19- 2021			

966693/2022/O/o DIRECTOR/QAC/TRACK/RDSO

## PART A: TECHNICAL REQUIREMENTS FOR THERMIT PORTIONS

### 3.0 SUPPLY OF THE “PORTIONS”

3.1 The ‘portions’ shall be submitted for acceptance batch wise as per following provisions:

- a) The manufacturers shall have **ISO 9001:2015** certifications. A batch may consist of 600 portions or part thereof manufactured on the same day from similarly treated raw materials and processing and mixing of all ingredients being done completely under automation by adequate and separate feeder channels. (The nature and category of complete automation and process control will be certified by the inspecting authority for permitting such batch). However, if automatic working of any of the feeder channels gets stopped, the production shall be stopped.
- b) Batch numbering shall be given year-wise in eight-digit code, whose first two digits will indicate the year of manufacture, next two digits will indicate the month of manufacture and the balance 4 digits, the serial number of the batch. The batch number at the beginning of each year shall, therefore, commence from 0001.

3.2 Every portion shall be packed in a moisture proof bag of Polyethylene to IS:9738, “Indian Standard Specification for Polyethylene bags for general purposes” Grade HM HDPE of 150-micron thickness which shall be sealed so as to make it airtight. The Polyethylene bag shall then be packed in a heavy duty bag made of New cloth to IS:187 or any other superior packaging approved by RDSO. The open end of this packaging shall be stitched and sealed in such a manner that there is no access to the ‘portion’ without damaging the bag / packaging or breaking its seal.

3.3 Following particulars shall be indicated on two similar labels – One placed inside the Polyethylene bag containing the portion and the other outside with the seal on the bag: -

- i) Batch No.
- ii) Portion No.
- iii) Date of manufacture
- iv) The section of rail to be welded
- v) The grade of rail to be welded
- vi) Welding technique
- vii) Automatic Tapping/ Manual Tapping
- viii) Insignia of the firm
- ix) Any other information

3.4 In order to have ease in identification of portions of various rail sections & grade as well as various techniques in field by welder, the packing of portions shall be done as under: -

ALOK NATH GUPTA <small>Digitally signed by ALOK NATH GUPTA Date: 2022.02.05 12:48:26 +05'30'</small>	Jaina Ram Meena <small>Digitally signed by Jaina Ram Meena Date: 2022.02.05 13:20:57 +05'30'</small>	SACHIN VERMA <small>Digitally signed by SACHIN VERMA Date: 2022.02.05 18:01:44 +05'30'</small>	Printed:
Prepared By: SSE/Track	Checked By: DD/Track/W	Issued By: DST-5	Page 6 of 63

### 3.4.1 52 Kg & above Rail Sections:

- (i) The portion of 52 Kg and above rail sections shall be packed in bags of different colour as per Rail Grades and combination of Rail grades. The colour of bags containing portions shall be as per table below:

S.No.	Rail grade	Colour
1.	72 UTS	Red
2.	90 UTS	Green
3.	R260	Violet
4.	1080 HH	Yellow
5.	1175 HT	Blue
6.	R260 with 90 UTS	Orange
7.	R260 with 1175 HT	Pink
8.	1175 HT with 90 UTS	Brown

- (ii) The Insignia of the firm and rail section (52 Kg/ 60 Kg / 60E1 etc.) shall be printed in contrast colour on the exterior of the cloth bag of above mentioned colour so that it is clearly visible.
- (iii) For manual tapping system portions shall be marked with Bold Letter “M” and for auto tapping system Bold Letter “ATT” shall be marked on the bag in same colour as used for marking the Rail Section. The letter size indicating Rail section & Tapping System shall be of minimum 150 mm height. The marking on Bags will be done on both the faces as per following example:

**52 Kg (M):** for 52 Kg Rail Section with Manual Tapping System

**52 Kg (ATT):** for 52 Kg Rail Section with Automatic Tapping System

### 3.4.2 Rail Sections below 52 Kg:

The portions for Rail section below 52 Kg, i.e. 90R, 75R & 60R shall be packed in White bags. The Insignia, Rail section shall be marked as per the colour scheme for the rail grade given at Para 3.4.1 (i).

- 3.5** The bags containing portion shall be packed in a sturdy wooden/Heavy duty corrugated card board/Metallic container. No container with the portion bags shall weigh more than 60 kg. Any bag of ‘portion’ found damaged at the time of delivery shall NOT be accepted.

The container shall have a coloured strip of 75mm width printed at the middle of the box as per the colour scheme given in the para 3.4 above of this specification. The coloured strip shall run at the centre of faces having lesser area and top of the

ALOK NATH GUPTA <small>Digitally signed by ALOK NATH GUPTA Date: 2022.02.05 13:46:26 +05'30'</small>	Jaina Ram Meena <small>digitally signed by jaina ram meena Date: 2022.02.05 13:47:01 +05'30'</small>	SACHIN VERMA <small>Digitally signed by SACHIN VERMA Date: 2022.02.06 18:01:44 +05'30'</small>	Printed:
Prepared By: SSE/Track	Checked By: DD/Track/W	Issued By: DST-5	Page 7 of 63

container. The insignia of the firm, rail section and tapping system shall also be printed on the exterior of the container on the other two faces having larger area. The rail section and tapping system ('M' for Manual tapping system or ATT for auto tapping system) be printed in letters of 25mm width (minimum) having overall 150mm height (minimum).

**4.0 ACCEPTANCE TESTS:  
NORMAL INSPECTION**

Two portions shall be randomly selected per batch and weight of each portion shall be within ± 0.25% of the approved weight of the portion which shall be recorded by the inspector.

Both portions shall be utilized for execution of test weld as per approved parameters for AT Welding technique. One joint each shall be made with maximum gap and minimum gap respectively by considering the tolerance specified for nominal gap as specified in para 2.5 of this specification.

**TIGHTENED INSPECTION**

Tightened inspection shall be implemented as soon as two out of five consecutive batches have been non-acceptable on original inspection.

In tightened inspection, three portions shall be randomly selected per batch and weight of each portion shall be within ± 0.25% of the approved weight of the portion which shall be recorded by the inspector. All the three portions shall be utilized for execution of test weld as per approved parameters for AT Welding technique. At least one joint each shall be made with maximum gap and minimum gap respectively by considering the tolerance specified for nominal gap as specified in para 2.5 of this specification.

**SWITCHING FROM TIGHTENED TO NORMAL INSPECTION**

When tightened inspection is carried out, normal inspection shall be reinstated when five consecutive batches have been considered acceptable.

While executing the test joint, characteristics of the Alumino-thermic reaction, i.e. whether it is quiet, normal or boiling shall be observed and if the reaction is found to be boiling, the batch shall be rejected. The reaction and tapping shall be within 20 ± 3 seconds for manual tapping. In case of A.T. welding technique with Auto tapping thimble/ One shot crucible, the reaction and tapping time shall conform to the tapping time range approved for the particular AT welding technique, as indicated in approval certificate and QAP of Firm. Following tests shall be conducted for assessing the quality of portion:

ALOK NATH GUPTA <small>Digitally signed by ALOK NATH GUPTA Date: 2022.02.25 13:46:26 +05'30'</small>	Jaina Ram Meena <small>Digitally signed by Jaina Ram Meena Date: 2022.02.25 13:29:57 +05'30'</small>	SACHIN VERMA <small>Digitally signed by SACHIN VERMA Date: 2022.02.06 18:01:44 +05'30'</small>	Printed: Page 8 of 63
Prepared By: SSE/Track	Checked By: DD/Track/W	Issued By: DST-5	



- i) Visual Surface Examination as per Para 4.1.
- ii) Checking of weld metal dimensions as per Para 4.2.
- iii) Ultrasonic test on test weld as per Para 4.3.
- iv) Mechanical and metallurgical test as per Para 4.4 except for “Fusion Zone Shape and dimension” as mentioned in para 4.4.4.
- v) Weld metal chemistry test as per Para 4.5.

#### 4.1 Visual Surface Examination

Welded joint shall be cleaned and examined carefully to detect any visible defect like cracks, blow holes, shrinkage, mismatch, surface finish (smooth surface finish required) etc. Joint which shows visible defect shall be considered as defective.

The bottom of the joint shall be checked by feeling with fingers as well as inspecting with the help of a mirror for presence of `fins` at the parting line of the mould. If fin is observed in joint, the joint shall be considered as defective.”

#### 4.2 Checking of weld metal dimensions

Weld metal dimensions of test weld shall be compared with approved weld metal dimensions of that particular AT Welding technique and it shall be within the range specified as mentioned in the approval of the technique.

#### 4.3 Ultrasonic test on test weld

Ultrasonic test on test weld shall be carried out as per procedure laid down for Ultrasonic testing of AT Welds by hand probing in ‘Manual for Ultrasonic testing of rails & welds’ Revised, 2012” along with its latest revision and updated correction slips, issued by RDSO, Lucknow. In case by the ultrasonic testing, weld is in DFW(O) or DFW (R) category, the joint shall be considered as defective. The Position of any apparent defects found by ultrasonic testing shall be recorded so that they may be revealed by sectioning. Cuts shall be positioned at least 5mm from any apparent defects located by the ultrasonic testing. For each defect, the size shall be determined by progressively grinding or machining and measuring until the maximum dimension is found.

#### 4.4 Mechanical and Metallurgical tests on test welds

- 4.4.1 Two new rail pieces of same section and grade, each minimum 650 mm long, shall be used to make test weld joints. The welded joint shall be made as per the technique offered by the manufacturer. The rail table and sides of the rail head shall be finished to the geometrical tolerances specified in Clause 18.2.

ALOK NATH GUPTA Digitally signed by ALOK NATH GUPTA Date: 2022.02.05 12:44:26 +05'30'	Jaina Ram Meena Digitally signed by Jaina Ram Meena Date: 2022.02.05 12:29:57 +05'30'	SACHIN VERMA Digitally signed by SACHIN VERMA Date: 2022.02.06 18:01:44 +05'30'	Printed:
Prepared By: SSE/Track	Checked By: DD/Track/W	Issued By: DST-5	Page 9 of 63

#### 4.4.2 Hardness test

Brinell hardness test shall be carried out at the welded zone, heat affected zones and parent metal of the rails in accordance with IS: 1500, “Method for Brinell Hardness test for steel”. The test shall be done on the top surface of the head of the test weld with a ball of 10 mm Dia. and a test load of 3000 kg maintained for 10 secs. The average hardness values of different rail chemistry on rail running surface of unaffected parent rail as per testing procedure and provisions specified in IRS/T-12-2009 along with its latest revision and updated correction slips are given in Table 1A for reference –

**Table - 1A**

Type of rail	72 UTS rail	90 UTS rail	R260 rail	1080 Head Hardened rail	1175 HT grade rail
Running Surface Hardness (BHN)	229*	Min 260	260-300	340-390	350 -390

\* For 72 UTS rail, average hardness (BHN) is 229

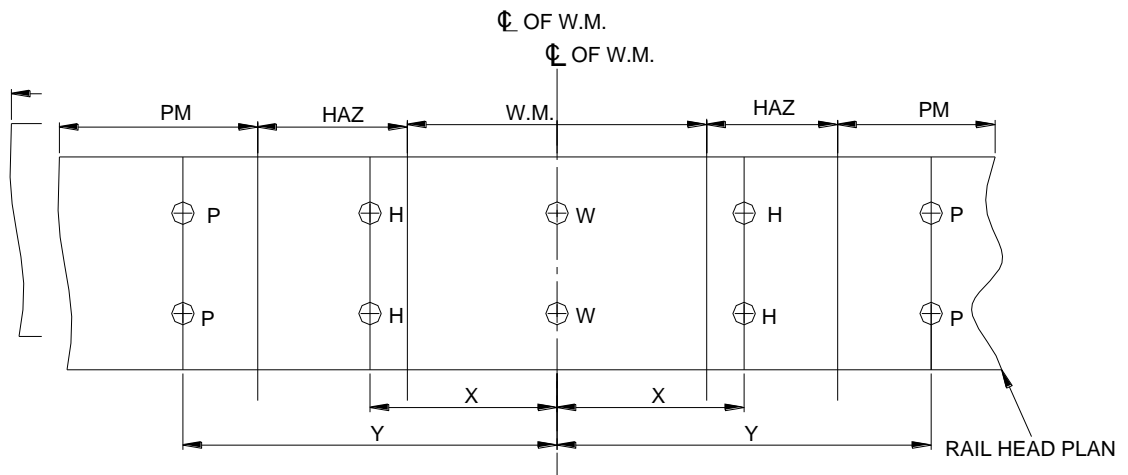

**Fig.1**

The average hardness number (of two readings) determined for the weld metal (WM), heat affected zone (HAZ) and parent metal (PM) at location shown as ‘W’ ‘H’ & ‘P’ respectively in fig. 1 shall be as per table – 1B given below:

- (i) For 25mm gap SKV welding & for any preheating device used.
- (a) For 52 Kg Section

X = 40 mm  
Y = 100 mm

(b) For 60 Kg / 60 E1 Section

X = 45 mm  
Y = 100 mm

(ii) For 50mm gap combination joint welding & for any preheating device used

X = 60 mm  
Y = 120 mm

(iii) For 75 mm wide gap welding & for any preheating device used

X = 80 mm  
Y = 150 mm

**Table 1B**

S. No.	Rail Section/ Grade	Hardness BHN	
		Weld Metal (W) (Weld centre-line)	Heat affected zone(H) (at locations shown in Fig. 1 above)
1.	72 UTS rail of all sections with normal & wide gap	229 + 20 - 0	± 20 of actual parent metal hardness (location 'P')
2.	90 UTS (880 grade) rails of all sections with normal & wide gap	265 + 30 - 0	+30 to -10 of actual parent metal Hardness (Location 'P')
3.	52 kg (90 UTS) Vs 90R (72 UTS) combination joint with 50mm gap	265 + 30 - 0	+30 to -10 of actual parent metal Hardness (Location 'P')
4.	60 kg (90 UTS) Vs 52kg (90 UTS) combination joints with 50mm gap	265 + 30 - 0	+30 to -10 of actual parent metal Hardness (Location 'P')
5.	60kg, 1080 H.H. rail,	321 (min.)	Not less than [actual parent metal hardness (Location 'P') – 60] BHN
6.	60 kg / 60 E1, R260 grade rail	265 + 30 - 0	+30 to -10 of actual parent metal hardness (location 'P')
7.	60 kg / 60 E1, 1175 HT grade rail	350±20	Not less than [Actual parent metal hardness (location

ALOK NATH GUPTA <small>Digitally signed by ALOK NATH GUPTA Date: 2022.02.05 12:44:26 +05'30'</small>	Jaina Ram Meena <small>Digitally signed by Jaina Ram Meena Date: 2022.02.05 12:29:57 +05'30'</small>	SACHIN VERMA <small>Digitally signed by SACHIN VERMA Date: 2022.02.06 18:01:44 +05'30'</small>	Printed:
Prepared By: SSE/Track	Checked By: DD/Track/W	Issued By: DST-5	Page 11 of 63

			'P')-60] BHN
--	--	--	--------------

**Note:** For Combination Joint of 60kg (R260) Vs 52kg (90UTS) rail with 50mm gap or Joint of 60kg (R260) Vs 60kg (90UTS) rail with 25mm nominal gap, Hardness values corresponding to R260 grade rail as specified above shall be considered.

Similarly, for AT welding Joints of 60kg (90UTS) Vs 60kg/60E1 (1175 HT grade) rails and 60kg/60E1 (R260) Vs 60kg/60E1 (1175 HT grade) rails, with 25 mm Nominal gap, Hardness values corresponding to 60kg/60E1 (1175 HT grade) rail as specified above shall be considered.

Rail used for AT welding shall be confirming to IRST-12-2009 along with its latest revision and updated correction slips. Certificate regarding parent metal hardness shall be provided by AT weld portion manufacturer firms at the time of approval of AT welding technique and whenever required by RDSO.

#### 4.4.3 Transverse breaking load test

4.4.3.1 The test weld shall be supported on cylindrical or semi cylindrical supports having a distance of one meter between them from centre to centre. The weld shall be at the centre of the span and loaded in such manner that the foot of the rail is in tension. The diameter of mandrel and the supports shall be between 30 to 50mm. The load shall be gradually increased (rate of loading shall not exceed 2.5 t/sec) till rupture occurs. The test weld shall withstand minimum transverse breaking load as indicated in column 4 of Table-2. The deflection at center at the actual transverse breaking load shall not be less than that specified in column 5 of Table-2.

**Table – 2**

S. No.	Rail Type	Rail Section	Min. transverse breaking load in tonnes	Min. deflection in mm at the centre at the actual transverse breaking load
1	2	3	4	5
A.	72 UTS to IRS T-12 for normal gap welding & wide gap (75 mm) welding	60R	50	15
		75R	55	15
		90R	65	15
		52Kg	85	18
		60 Kg	95	18
B.	90 UTS to IRS T-12 for normal & wide gap(75mm) welding	75R	60	15
		90R	80	15
		52kg	90	15

ALOK NATH GUPTA Digitally signed by ALOK NATH GUPTA Date: 2022.02.05 12:44:26 +05'30'	Jaina Ram Meena Digitally signed by Jaina Ram Meena Date: 2022.02.05 12:44:26 +05'30'	SACHIN VERMA Digitally signed by SACHIN VERMA Date: 2022.02.06 18:01:44 +05'30'	Printed:
Prepared By: SSE/Track	Checked By: DD/Track/W	Issued By: DST-5	Page 12 of 63

		60 kg	115	15
C.	Combination joint (50mm gap)	*52kg (90 UTS)/ 90R (72 UTS) 60kg (90 UTS)/ 52kg (90 UTS)	70  90	15  15
D.	1080 Head Hardened Rails to IRS T-12 for normal gap welding	60kg	115	12
E.	60 kg / 60 E1, R260 grade rail for Normal & wide gap (75mm) welding	60kg / 60 E1	122.5	15
F.	60 kg / 60 E1, 1175 HT grade rail for Normal & wide gap (75mm) welding	60kg / 60 E1	122.5	12

**\* 90UTS portion shall be used in 52Kg/90R combination joints.**

**Note:** For Combination Joint of 60kg (R260) Vs 52kg (90UTS) rails with 50mm gap – transverse breaking load and min. deflection values corresponding 52kg (90UTS) joint and for Joint of 60kg (R260) Vs 60kg (90UTS) rails with 25mm nominal gap - transverse breaking load and min. deflection values corresponding to 60kg/60E1, R260 grade rail as specified above shall be considered.

Similarly, for AT welding Joints of 60kg (90UTS) Vs 60kg/60E1 (1175 HT grade) rails and 60kg/60E1 (R260) vs 60kg/60E1 (1175 HT grade) rails, with 25 mm Nominal gap, transverse breaking load and min. deflection values corresponding to 60kg/60E1, 1175 HT grade rail as specified above shall be considered.

4.4.3.2 If the fracture does not occur through weld, a slice shall be cut transversely at the weld and etched in boiling 1:1 Hydrochloric acid for about 20 minutes to determine casting defects if any.

**4.4.3.3 Macro Examination:**

The fractured surface of the weld, or in case where macro - etching is done on transverse section through the joint, shall not show defects such as blow holes, porosity and inclusions etc. having individual size greater than 2mm dia. There shall not be more than three defects of size  $\leq$  2mm dia. The distance between two defects of size  $\leq$  2mm dia. shall not be less than 20mm. The macro - etched transverse section shall not show cracks of length 2mm or greater. The defects shall not be interconnected and none of these shall extend up to the outer surface of the weld. There shall not be any lack of fusion and clustered porosities. The

fractured surface shall also not show the presence of accretions or mirror like surface and shall be crystalline in appearance.

#### 4.4.4 Fusion Zone-Shape and dimension

After macro examination, measurements of the fusion zone shall be made on the cuts illustrated in Fig. 2 the minimum distance X (Fig. 2) between the parent rail ends before welding and the fusion line shall be equal to or greater than 3mm. The measurement of X shall be made using datum marks to locate the original position of the rail ends.

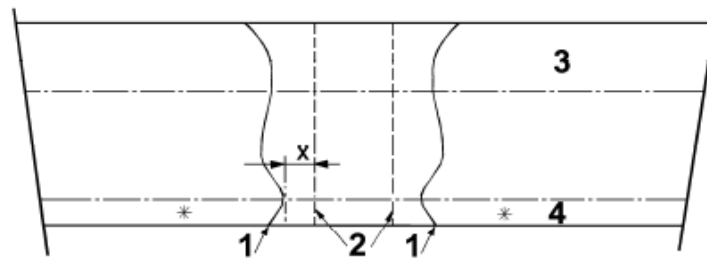

#### Key

- \* Datum marks on foot tip
- 1 Fusion line
- 2 Rail ends before welding
- 3 Rail head
- 4 Rail foot

**Figure-2: Shape of fusion zone on the etched longitudinal vertical section**

The fusion zone shall exhibit a symmetrical shape about the welding gap. The visible heat affected zones on each side of the weld shall be measured on the rail running surface centre line. The visible heat affected zone shall be symmetrical about the longitudinal axis of the rail and transverse axis of the weld.

#### 4.5 Weld Metal Chemistry Test:

Full chemical analysis is to be conducted on the rail weld running surface at 10mm away from the weld transverse axis. The chemical composition of the weld so determined shall conform to the following:

ALOK NATH GUPTA <small>Digitally signed by ALOK NATH GUPTA Date: 2022.02.05 12:44:26 +05'30'</small>	Jaina Ram Meena <small>digitally signed by jaina ram meena Date: 2022.02.06 12:29:57 +05'30'</small>	SACHIN VERMA <small>Digitally signed by SACHIN VERMA Date: 2022.02.06 18:01:44 +05'30'</small>	Printed:
Prepared By: SSE/Track	Checked By: DD/Track/W	Issued By: DST-5	Page 14 of 63

ISO 9001:2015	Document No:IRST-19-2021	Version No: 7	Effective Date: 01.02.2022
966693/2022/O/o DIRECTOR/QAC/TRACK/RDSO			
Document Title: Indian Railway Standard Specification for Fusion Welding of Rails By Alumino – Thermic Process Serial No. IRST-19- 2021			

Grade of rail	C %	Mn %	+Si %	S %	P %	V %*	Mo %*	Al%	Cr %	Cu %	Ni %	Sn %	Sb %	Ti %	Nb %
90UTS/ R260, 1080 HH	0.45	0.80	0.50	0.05	0.05	0.10	0.10	0.02	0.20	--	--	--	--	--	--
	- 0.70	- 1.30	(max)	(max)	(max)	- 0.15	- 0.25	- 0.60	(max)						
72 UTS	0.40	0.80	0.50	0.05	0.05	0.10	0.10	0.02	0.20	--	--	--	--	--	--
	- 0.55	- 1.20	(max)	(max)	(max)	- 0.15	- 0.25	- 0.60	(max)						
1175 HT	0.50	0.50	0.00	0.00	0.00	0.10	0.10	0.02	0.00	0.00	0.00	0.00	0.00	0.00	0.00
	- 1.00	- 1.40	- 1.75	- 0.035	- 0.035	- 0.65	- 0.40	- 0.60	- 0.80	- 0.20	- 0.20	- 0.02	- 0.02	- 0.05	- 0.02

Working range of each element for 1175 HT grade shall be as mentioned below

SN	Element	Working range
1	Carbon	± 0.12
2	Silicon	± 0.25
3	Manganese	± 0.20
4	Phosphorous	Not Specified
5	Sulphur	Not Specified
6	Chromium	± 0.20
7	Aluminium	± 0.20
8	Vanadium	Not Specified
9	Niobium	Not Specified
10	Nickel	Not Specified
11	Copper	Not Specified
12	Tin	Not Specified
13	Antimony	Not Specified
14	Titanium	Not Specified
15	Molybdenum	Not Specified

The firm shall define the mean value for each element with a working range in Table above. Actual values shall not vary by more than the working range and this range shall fit within the permitted range

\* Either Vanadium or Molybdenum may be used as grain refiner.

+In case single shot crucible is used, the maximum limit of Si% may be taken as 1.20 % for 90 UTS /R260/1080 Head Hardened rail, and 72UTS rails.

Weld metal chemistry for AT welding Joint of 90UTS / R260 Vs 1175 HT grade rails shall be same as that specified for 1175 HT grade rails.

ALOK NATH GUPTA Digitally signed by ALOK NATH GUPTA Date: 2022.02.05 13:44:26 +05'30'	Jaina Ram Meena Digitally signed by Jaina Ram Meena Date: 2022.02.05 13:29:07 +05'30'	SACHIN VERMA Digitally signed by SACHIN VERMA Date: 2022.02.06 18:01:44 +05'30'	Printed:
Prepared By: SSE/Track	Checked By: DD/Track/W	Issued By: DST-5	Page 15 of 63

**4.6 Rejection of Batch**

If the results of any of the tests referred to in clause 4.1, 4.2, 4.3, 4.4.2, 4.4.3.1, 4.4.3.3 and 4.5 are found to be unsatisfactory for any of the test weld as specified in para 4.0 of this specification, the batch will stand rejected.

**5.0 DISPOSAL OF REJECTED BATCH:**

In the event of a batch failing to comply with the requirement of Para 4, the manufacturer will dispose off the rejected portions by igniting off the portions and converting them into metallic form at a safe place in presence of RDSO officials. The rejected batch shall be kept separately duly marked “Rejected” on each pack in red. Proper record of disposal shall be maintained.

**6.0 ACCEPTANCE**

**6.1** Acceptance shall be done batch wise. Every individual batch that satisfies the conditions prescribed in this specification shall be accepted. Each bag containing the portion shall be sealed by the manufacturer and the container shall be suitably stamped/sealed by the Inspecting Officer. The stamp/seal shall be such that it shall not be possible to open the container without breaking stamp/seal.

**6.2** The manufacturer shall dispatch the accepted portions immediately to the consignee so as to reach consignee within 30 days from the date of issue of inspection certificate.

**7.0 DISPOSAL OF REJECTED PORTIONS**

In case the batch fails to meet the requirements of clause 4, it shall be rejected. The rejected portions shall be separately stored and a proper accountal shall be kept. The disposal of these rejected portions shall be carried out as per clause 5.0 of this specification.

**8.0 TESTING FACILITIES**

The manufacturer shall, at his own expense, supply all labour, materials, consumables, rail pieces and appliances for testing carried out in presence of the Inspecting Officer, in his own premises or at any other acceptable place in accordance with this specification.

**9.0 INSPECTION OF PREMISES AND RECORDS**

The purchaser or the Inspecting Officer shall have free access to the premises of the manufacturer at all reasonable times. They shall be at liberty to inspect all the records and the manufacture of ‘portions’ at any stage.

<b>ALOK NATH GUPTA</b> <small>Digitally signed by ALOK NATH GUPTA Date: 2022.02.05 13:44:26 +05'30'</small>	<b>Jaina Ram Meena</b> <small>digitally signed by jaina ram meena Date: 2022.02.05 13:29:57 +05'30'</small>	<b>SACHIN VERMA</b> <small>Digitally signed by SACHIN VERMA Date: 2022.02.06 18:01:44 +05'30'</small>	<b>Printed:</b> Page 16 of 63
Prepared By: SSE/Track	Checked By: DD/Track/W	Issued By: DST-5	



**PART B: APPROVAL OF “PORTIONS MANUFACTURERS”**

- 10.0 The approval of ‘Portion manufacturer’ shall be given separately for each rail section/grade/chemistry of rail and for each technique of welding.
- 10.1 The variants for various parameters of A.T. welding technique are given below. Permitted combination of following variants shall be treated as a welding technique.

S.No	Parameter	Variants		
1.	Rail section/ grade/ chemistry	Rail section/ grade/chemistry chosen shall be as per their respective latest version of IRST-12.		
2.	Parameters forming Technique of welding	Pre-heating system	Compressed Air petrol/ Compressed Air LPG (Mechanical pressurization) or similar	Oxy LPG/ Oxy Propane or similar
3.		Pre-fabricated mould	3 piece mould	
			Manually pressed	Core shooted
4.		Tapping system	Auto tapping	
5.		Crucible system	Single shot #	

**NOTE:-**

- (i) The firm shall furnish the details of preheating equipment along with drawing of preheating burner and its position with respect to rail top and center line of mould for preheating.
- (ii) The firm shall furnish the details and drawing for positioning of single shot crucible with respect to rail top and center line of mould. The tapping height with respect to rail top shall also be mentioned in the drawing.
- (iii) The agency / firm shall furnish critical process timing viz. Preheating time, tapping time, mould waiting time, time for passage of First train on AT weld etc for AT welding technique. The complete welding process starting from the cutting of rail to passage of first train shall be completed within the time period of 70 minutes for one AT weld.
- (iv) Pre heating system deployed shall have facility to record and save the pre heating parameters viz. pressure and time, firm details, welder details and weld location details for a particular weld along with facility to send these preheating parameters and related details automatically as SMS to concerned Railway officials immediately after finishing of preheating. It shall be possible to send

ALOK NATH GUPTA <small>Digitally signed by ALOK NATH GUPTA Date: 2022.02.05 12:48:26 +05'30'</small>	Jaina Ram Meena <small>digitally signed by jaina ram meena Date: 2022.02.05 12:29:57 +05'30'</small>	SACHIN VERMA <small>Digitally signed by SACHIN VERMA Date: 2022.02.06 18:01:44 +05'30'</small>	Printed:
Prepared By: SSE/Track	Checked By: DD/Track/W	Issued By: DST-5	Page 17 of 63

this SMS simultaneously up to 10 mobile numbers. This facility shall be developed and implemented in all Pre heating equipments by the firm within a time period of one year from date of implementation of this specification i.e. IRST-19:2020.

# Single shot crucible shall be considered only with pre-fitted Auto tapping thimble.

**10.2** For upgraded A.T. welding techniques offered in reference to clause 22 Part E of IRST-19 specification, approval shall be given to AT welding technique for each rail section/grade/chemistry separately irrespective of the other variants chosen.

**11.0 For the purpose of approval, the following definitions shall apply.**

**11.1** “Portion Manufacturer” shall mean the organization manufacturing the ‘portion’. In addition, the “Portion Manufacturer” may execute A.T. Welding of rail joints by his own technique approved by RDSO.

**11.2** “Approving Authority” shall be Director General, Research Designs & Standards Organization, Ministry of Railways, Manak Nagar, Lucknow – 226011 or his representative.

**12.0 PROCEDURE FOR APPROVAL OF “PORTION MANUFACTURERS”**

**12.1** The **Portion Manufacturer** (referred as ‘Firm’ here in after) will approach RDSO through “On-line vendor registration system” for approval of their firm for manufacturing of AT portions and welding of rail joints indicating the rail for which portion is being offered and the welding technique. If any firm is approved in the AT welding technique for 90UTS or R260 grade rail then only the firm, shall be allowed to develop the AT welding technique for 1175 HT grade rail.

**12.2** The application for approval shall be submitted by the firm as per Vendor Registration Guidelines available on RDSO website.

**12.3** The payments shall be made by means specified in Vendor Registration Guidelines available on RDSO website.

**12.4** If the information submitted by the applicant is prima facie found to be satisfactory, the approving authority can take a call to inspect the premises of the applicant for assessment or approving authority may grant dispensation from the assessment, particularly, if the applicant is already registered with RDSO for any Other AT welding Technique. Firm shall submit the internal test results of offered AT welding technique in prescribed proforma. In case assessment is required to be carried out then, only after the satisfactory assessment, internal test results of offered AT

welding technique in prescribed proforma shall be submitted. Lab evaluation will be carried out after internal test results are found satisfactory on scrutiny.

**12.5 Tests and trials for approval of “Portion Manufacturers”**

**12.5.1** The Portion Manufacturer shall manufacture a batch of 150 ‘portions’ at his own cost. 25 number samples shall be drawn at random by the Approving Authority and their weight be recorded. The weight of the portions shall be within  $\pm 0.25\%$  of the average weight. Following laboratory tests shall be carried out at the manufacturer’s work premises:

- i) Twelve test weld joints shall be made as per clause 4.4.1 in which six joints each shall be made with maximum gap and minimum gap respectively by considering the tolerance specified for nominal gap as specified in para 2.5 of this specification. While executing the test joints, characteristics of the Alumino-thermic reaction, i.e. whether it is quiet, normal or boiling shall be observed and if the reaction is found to be boiling, the technique shall be rejected.

The reaction and tapping time for AT welding technique with Auto tapping thimble/ one shot crucible, shall conform to the tapping time range indicated in respective QAP.

**ii) The joints shall be subjected to following tests:**

- a) **Visual Surface Examination** of all the joints, as per clause 4.1 of this specification.
- b) **Ultrasonic test** on all the joints shall be carried out as per procedure laid down for Ultrasonic testing of AT Welds in ‘Manual for Ultrasonic testing of rails & welds’ Revised, 2012” with its latest revision and updated correction slips, issued by RDSO, Lucknow. In case the weld is in DFW(O) or DFW (R) category, the joint shall be considered as defective. The Position of any apparent defects found by ultrasonic testing shall be recorded so that they may be revealed by sectioning. Cuts shall be positioned at least 5mm from any apparent defects located by the ultrasonic testing. For each defect, the size shall be determined by progressively grinding or machining and measuring until the maximum dimension is found.
- c) **Brinell Hardness Test** on all the joints as per clause 4.4.2 of this specification.
- d) **Transverse load and deflection test** on six randomly selected joints by taking three each from the joints with maximum gap and minimum gap respectively, as per clause 4.4.3 of this specification.
- e) **Weld metal chemistry test** shall be conducted on above six test joints as per clause 4.5 of this specification.
- f) **Macro examination** shall be undertaken on deep etched longitudinal section across the weld on the remaining six joints. This examination shall not reveal any lack of

ALOK NATH GUPTA <small>Digitally signed by ALOK NATH GUPTA Date: 2022.02.05 12:44:26 +05'30'</small>	Jaina Ram Meena <small>digitally signed by jaina ram meena Date: 2022.02.05 12:29:57 +05'30'</small>	SACHIN VERMA <small>Digitally signed by SACHIN VERMA Date: 2022.02.06 18:01:44 +05'30'</small>	Printed:  Page 19 of 63
Prepared By: SSE/Track	Checked By: DD/Track/W	Issued By: DST-5	

fusion or cracks. The Macro examination shall not show defects such as blow holes, porosity and inclusions etc. having individual size greater than 2mm dia. There shall not be more than three defects of size  $\leq 2$ mm dia. The distance between two defects of size  $\leq 2$ mm dia. shall not be less than 20mm. The macro - etched transverse section shall not show cracks of length 2mm or greater. The defects shall not be interconnected and none of these shall extend up to the outer surface of the weld. There shall not be any lack of fusion and clustered porosities.

For confirming any defect found in macro examination, magnetic crack detection test shall also be carried out.

- g) **Microscopic examination:** Samples for microscopic examination shall be taken and prepared in accordance with Annexure-1. The structure of the fusion zone shall conform with that defined by the supplier firm, which shall not contain martensite or bainite examined at x 100 magnification. The visible heat affected zone shall not contain any bainite or martensite examined at x 100 magnification. The structure shall be recorded. For 1080 HH and 1175 HT grade rail, ASTM grain size number shall not be less than 3.
- h) **Fusion Zone-Shape and dimension:** After macro examination Fusion Zone-Shape and dimension shall be recorded on all six joints tested for macro examination as per para 4.4.4 of this specification. The minimum distance X (Fig 2) between the parent rail ends before welding and the fusion line shall be equal to or greater than 3mm.

**12.5.2 Rejection of A.T. Welding Technique:**

If the results of any of the tests referred to in clause 12.5.1 above fail to meet the requirements of the test, the technique shall be rejected. The technique can be reoffered by the firm as per provisions of Vendor Registration Guidelines available on RDSO website

**12.6** The approving authority shall have free access to the premises of the portion manufacturer at all reasonable times. The portion manufacturer shall furnish all the technical data to the approving authority as and when call for.

**13.0 FATIGUE TEST**

**13.1** Fatigue testing of thermit welding technique shall be arranged by the firm at his own expense. Following principle shall be followed:

- i) For 90UTS metallurgy – Anyone section out of 52kg / 60kg (when both the sections have been developed the lighter section shall be selected for fatigue testing).
- ii) For R260 metallurgy – Anyone section out of 60Kg / 60E1
- iii) For 1175 HT metallurgy – Anyone section out of 60Kg / 60E1

ALOK NATH GUPTA <small>Digitally signed by ALOK NATH GUPTA Date: 2022.02.05 12:44:26 +05'30'</small>	Jaina Ram Meena <small>digitally signed by jaina ram meena Date: 2022.02.05 13:20:17 +05'30'</small>	SACHIN VERMA <small>Digitally signed by SACHIN VERMA Date: 2022.02.06 18:01:44 +05'30'</small>	Printed: Page 20 of 63
Prepared By: SSE/Track	Checked By: DD/Track/W	Issued By: DST-5	

ISO 9001:2015	Document No:IRST-19-2021	Version No: 7	Effective Date: 01.02.2022
Document Title: Indian Railway Standard Specification for Fusion Welding of Rails By Alumino – Thermic Process Serial No. IRST-19- 2021			

966693/2022/O/o DIRECTOR/QAC/TRACK/RDSO

- iv) Development of any other AT Welding technology such as wider gap, 1080 Head Hardened rails shall also be got separately fatigue tested before standardization. However, one section for one technique shall be required to be fatigue tested.
- v) For AT welding joints of different grade of Rails viz R260 to 90 UTS, R260 to 1175HT, 90 UTS to 1175HT grade rails - Anyone section out of 60Kg / 60E1.

**13.2** The weld samples shall be tested in a recognized laboratory/test centre.

**13.3** Following scheme shall be followed for fatigue testing of thermit welded rail joints: -

- i) Three weld samples shall be made in presence of RDSO representatives.
- ii) The weld samples shall be made with one meter long new rail pieces to have an overall length of 2.0m. The rail and joint shall be ultrasonically tested.
- iii) Testing shall be done for stress ranges of tensile 20 kg/mm<sup>2</sup> to compressive 4 kg/mm<sup>2</sup> (these are the stresses on the bottom surface of rail foot). The test frequency shall be anyone frequency between 8.33 Hz to 12 Hz. Details of Fatigue testing equipment is at **Annexure- 4** of this specification
- iv) A joint shall be deemed to have passed if it withstands a minimum of 2 million cycles except for joints of 1175 HT grade rails. For joints of 1175 HT grade rails, a joint shall be deemed to have passed if it withstands a minimum of 5 million cycles. For AT welding joints of different grade of Rails viz R260 to 90 UTS, R260 to 1175HT, 90 UTS to 1175 HT grade rails - A joint shall be deemed to have passed if it withstands a minimum of 2 million cycles
- v) The technique shall be deemed to have cleared fatigue test if all the three samples pass the above test.
- vi) Subject to the results of the tests in clause 12 and 13 above being satisfactory, firm shall be approved provisionally in the list of “RDSO vendors for developmental orders” for a period of two years.

#### **13.4 Rejection of A.T. Welding technique:**

If the results of Fatigue test referred in clause 13.3 above, failed to meet the requirements of the fatigue test, the technique shall be rejected. The technique can be reoffered by the firm as per provision of Vendor Registration Guidelines available on RDSO website.

#### **14.0 FIELD TRIALS**

- 14.1** Subject to the results of the tests in clause 12 and 13 above being satisfactory, firm shall be approved provisionally in list of ‘RDSO vendors for development orders’. 100 weld joints (for AT welding technique of same grade of rails) by the firm in first

ALOK NATH GUPTA Digitally signed by ALOK NATH GUPTA Date: 2022.02.05 12:44:26 +05'30'	Jaina Ram Meena Digitally signed by jaina ram meena Date: 2022.02.05 12:44:26 +05'30'	SACHIN VERMA Digitally signed by SACHIN VERMA Date: 2022.02.06 18:01:44 +05'30'	Printed: Page 21 of 63
Prepared By: SSE/Track	Checked By: DD/Track/W	Issued By: DST-5	

contract shall be executed in presence of Zonal Railway representative, not below the rank of JE/SSE. These field trial joints shall be monitored by concerned Zonal Railway as trial joints for a period of one year or till passage of 10 GMT traffic over the joint, whichever is earlier. Considering requirement of welded joints (For AT welding technique of different grades of rails) being very less In number and joints scattered over large stretches and larger time consume, field trial shall not be required for approval of technique for combination welding. The trial joints shall be distinctly marked by painting letter “T” on the web of the rail beyond 300 mm from the joints. Field trial report shall be prepared as per Annexure - 5 and submitted to the RDSO by the Zonal Railway after signature of firm’s representative and nominated Zonal Railway official not below the rank of JE/SSE and countersigned by concerned sectional ADEN.

**14.2** Ultrasonic test on field trial weld joints shall be carried out by the Zonal Railway as per procedure laid down for Ultrasonic testing of AT Welds in Manual for Ultrasonic testing of rails & welds’ Revised, 2012” along with its latest revision and updated correction slips, issued by RDSO, Lucknow. Up to a maximum of 1% defective welds shall be cut and re-welded by the firm at his own expense. If more than 1% joints are found defective, further welding shall be discontinued considering the technique to be unsatisfactory. All the defective joints shall be removed from track by the firm at his own expense. The initial USFD report shall be prepared as per Annexure – 5A and submitted to the RDSO.

**14.3** After a passage of 10 GMT traffic over the joints or a period of one year whichever is earlier, Zonal Railway shall conduct USFD test of the trial joint as per procedure given in “Manual for Ultrasonic testing of rails & welds’ Revised, 2012” along with its latest revision and updated correction slips, issued by RDSO, Lucknow. The USFD report shall be prepared as per Annexure – 5B and submitted to the RDSO.–Final inspection of trial joints shall be carried out as per clause 18 of this specification by Zonal Railway and Field Trial report shall be submitted as per proforma given in Annexure –5C jointly signed by the Firm’s representative and nominated Zonal Railway official not below the rank of JE/SSE and countersigned by concerned sectional ADEN. Failure of more than 1% joints of field trial (Including Ultrasonic examination) will render the technique unacceptable and firm shall be delisted from the list of “RDSO vendors for developmental orders for particular technique”. AT welding contract shall be short closed for particular technique. AT welded joints already executed by the firm shall be ultrasonically tested and good AT welded joints shall be allowed to remain in the Track. In case, the weld is in DFW (O) or DFW (R) category in the ultrasonic examination, the joint shall be considered as defective.

ALOK NATH GUPTA <small>Digitally signed by ALOK NATH GUPTA Date: 2022.02.05 13:44:26 +05'30'</small>	Jaina Ram Meena <small>digitally signed by jaina ram meena Date: 2022.02.05 13:29:07 +05'30'</small>	SACHIN VERMA <small>Digitally signed by SACHIN VERMA Date: 2022.02.06 18:01:44 +05'30'</small>	Printed:
Prepared By: SSE/Track	Checked By: DD/Track/W	Issued By: DST-5	Page 22 of 63

**14.4** After satisfactory field trial report, provisional approval of the firm in the “List of RDSO vendors for developmental orders” shall be regularized for a time period of 5 years from the date of provisional approval.

**15.0 REQUIREMENTS FOR UPGRADATION TO APPROVED A.T. WELDING TECHNIQUES**

**15.1** Up gradation to pre-heating system, tapping system, pre-fabricated mould and crucible system in **already approved A.T. welding techniques**, shall require assessment as described hereinafter. The basic technique and upgrades are defined in Table 4 below:

**Table 4**

S.No.	Parameters	Basic technique	Offered upgrade to basic technique	Remarks
1	Pre-heating system	Air petrol mixture with manual pressurisation	Compressed Air-petrol (mechanised pressurization), Oxy LPG, Oxy Propane or similar/superior	i) One or more upgrades can be offered simultaneously. ii) There shall be no change in weld metal dimensions in up-graded technique over approved limits for basic technique.
2	Tapping of molten metal	Manual tapping	Automatic tapping	
3	Type of Pre-fabricated mould	Two piece manufactured by manual pressing	Three piece manufactured by manual pressing, Three piece manufactured by core shooted technology (Machine pressing)	
4	Crucible system	Multiple use crucible	Single shot crucible	

**15.1.1** Three piece mould shall be manufactured as per the “Specification of 3-Piece Pre-Fabricated Mould Manufactured by A.T. Portion Manufacturers for use during A.T. Welding of Rails” given at **Annexure -2**.

**15.2** For approval of process up-gradation, the requirements of lab test (as per para 12.5), and fatigue test (as per para 13) shall be fulfilled for each rail section/grade separately.

**15.3** The execution and evaluation of field trial joints as per para 14 shall be undertaken post approval i.e. after the approval has been granted to the up-graded technique based on evaluation as per para 15.2 above. The approval shall be reviewed on fulfillment of GMT/Duration criteria for trial joints as prescribed in para 14.1 and continuation of the approval shall be subject to the performance of trial joints being found satisfactory as per para 14.2 & 14.3.

<p><b>ALOK NATH GUPTA</b> Digitally signed by ALOK NATH GUPTA Date: 2022.02.05 13:44:26 +05'30'</p>	<p><b>Jaina Ram Meena</b> Digitally signed by Jaina Ram Meena Date: 2022.02.05 13:22:57 +05'30'</p>	<p><b>SACHIN VERMA</b> Digitally signed by SACHIN VERMA Date: 2022.02.06 18:01:44 +05'30'</p>	<p>Printed:</p>
<p>Prepared By: SSE/Track</p>	<p>Checked By: DD/Track/W</p>	<p>Issued By: DST-5</p>	<p>Page 23 of 63</p>

## 16 PART C: PROCEDURE FOR APPROVAL OF AT WELDING SUPERVISORS AND WELDERS

**16.1** For the purpose of approval, the following definitions shall apply: -

“Welding Supervisor” shall mean a railway official with adequate knowledge and competence for supervising and executing Alumino Thermic welding of rail joints.

“Welder” shall mean an individual with adequate skill and competence for executing Alumino Thermic welding of rail joints at site.

The approval of Welders for execution of Alumino – Thermic welds at site shall be given separately for the following categories of welding techniques: -

- a) Welding of R260/ 90UTS/ 72UTS (52Kg & 60Kg/60E1) rails with standard gap
- b) Wide gap welding
- c) Welding of 1080 Head Hardened rails with standard gap
- d) Welding of 1175HT rails with standard gap

**16.2** Competency certificates for welding supervisors and welders of the zonal Railways shall be issued by the Thermit Portion Plant of Northern Railway at Lucknow or Thermit Welding Centre, (TWC), South-Central Railway at Vijayawada. Competency certificates for welders of firms shall be issued by DG (M&C) RDSO, Lucknow.

**16.3** For other than departmental welders, test weld joints will be made using any rail section at the discretion of the approving authority. Welders found competent shall be deemed to be fit for A.T. welding of all rail sections for the particular category as per clause 16.1. For execution of test weld joints, the welder desirous of obtaining approval shall have to utilize his own welding team, rails, implements and ‘portions’ procured from approved manufacturers.

**16.4** The firm shall pay, in advance, charges for certification of welders as per rates decided by RDSO for this purpose. Payment shall be made through SB Collect’ through ‘E-Payment to RDSO’ link under Vendor Interface on RDSO website ([www.rdsso.indianrailways.gov.in](http://www.rdsso.indianrailways.gov.in)).

**16.5** Six test welds shall be made by the welder and his team for the particular category of welding technique (as per clause 16.1) for which approval is sought. Following tests shall be carried out at the sponsoring firm’s works premises: -

- a) Ultrasonic test on test weld joints shall be carried out as per procedure laid down for Ultrasonic testing of AT Welds in ‘Manual for Ultrasonic testing of rails & welds’ Revised, 2012” along with its latest revision and updated correction slips,

ALOK NATH GUPTA <small>Digitally signed by ALOK NATH GUPTA Date: 2022.02.05 12:48:26 +05'30'</small>	Jaina Ram Meena <small>digitally signed by jaina ram meena Date: 2022.02.05 12:29:57 +05'30'</small>	SACHIN VERMA <small>Digitally signed by SACHIN VERMA Date: 2022.02.06 18:01:44 +05'30'</small>	Printed:
Prepared By: SSE/Track	Checked By: DD/Track/W	Issued By: DST-5	Page 24 of 63



ISO 9001:2015	Document No:IRST-19-2021	Version No: 7	Effective Date: 01.02.2022
Document Title: Indian Railway Standard Specification for Fusion Welding of Rails By Alumino – Thermic Process Serial No. IRST-19- 2021			

issued by RDSO, Lucknow. In case, the weld is in DFW(O) or DFW (R) category in the ultrasonic examination, the joint shall be considered as defective.

- b) The ultrasonically sound joints will be subjected to following tests:-
- Visual examination and joint geometry as per clause 18.1 and 18.2 respectively.
  - Brinell hardness test on all the test welds as per clause 4.4.2
  - Transverse load and deflection tests on any three test welds as per clause 4.4.3
  - Magnetic crack detection and macro examination of remaining three test welds longitudinally sectioned across the weld as per clause 12.5.1 (ii) (f).

**16.6** If the test results are satisfactory, a provisional competency certificate, valid for two years, shall be issued to the firm's welder. The provisionally approved welder's competency certificates shall be re-assessed by RDSO in case of firm's welder after two years of issue of provisional competency certificate then Regular Competency Certificate will be issued to the welder, which is valid for the period not more than five years.

For departmental welder and Welding Supervisor, TPP/Lucknow or TWC/Vijayawada issues

- Provisional competency certificate for departmental welder (valid for executing 100 joint or 6 months whichever is earlier) after successful completion of "Initial Course of Welders" (TW1 course).
- Regular competency certificate for departmental welder (valid for 2 years) if the defective weld percentage is less than 1% of the welds executed by the welder (Minimum 50 welds to be executed by the welder within 6 months), the result of the test weld and after successful completion of "Refresher Course for Welders" (TW2 course).
- The trained departmental welders shall attend "Refresher Course for Welders" (TW2 course) within 2 years of issue of regular competency certificate for revalidating their competency certificate.
- Welding Supervisor shall be issued competency certificate after successful completion of "training course for supervisors" (TW3). The welding supervisor shall not be normally required to undergo this course again.

**16.6.1** For the purpose of reassessment, the welder shall submit, to the approving authority, the following details duly countersigned by the concerned Assistant Engineer of Zonal Railway: -

ALOK NATH GUPTA <small>Digitally signed by ALOK NATH GUPTA Date: 2022.02.05 13:44:26 +05'30'</small>	Jaina Ram Meena <small>Digitally signed by jaina ram meena Date: 2022.02.05 13:29:37 +05'30'</small>	SACHIN VERMA <small>Digitally signed by SACHIN VERMA Date: 2022.02.06 18:01:44 +05'30'</small>	Printed:
Prepared By: SSE/Track	Checked By: DD/Track/W	Issued By: DST-5	Page 25 of 63

- a) A record of joints welded by him
- b) No. of joints failed in service

**16.6.2** Based on the above details and personal interview, the approving authority will issue competency certificate. Fresh competency certificate will have to be issued whenever there is a change in the process of welding or when a person who has been earlier trained and issued with a competency certificate has not been executing welding for a period of more than 2 years or the work done by him has been rated as unsatisfactory.

**16.6.3** Renewal of competency certificate will be made based on performance or actual testing.

**16.6.4** Following methodology shall be used for issuing the Identification Code Number for welders /supervisors of Railway or firm:

- a) Certificate number for welder/supervisors of Zonal Railway

The format for the certificate number of the welder/supervisor of the Zonal Railway shall be as follows:

A	A	B	B	B	B	C	C	C
---	---	---	---	---	---	---	---	---

- b) Certificate number for welders of portion manufacturers and welding contractors.

The format for the certificate number of the welders of the portion manufacturers and welding contractors shall be as follows:

A	A	B	B	B	B	C
---	---	---	---	---	---	---

Where,

A	A	Code number for the firm to which the welder/supervisor belongs i.e. 00 for AT portion manufacturing firms 01 for departmental welders 02-99 for welders of welding contractors. The codes shall be allotted for different contractual agencies undertaking AT welding of rails (other than portion manufacturers)
---	---	---

B	B	B	B	Specific person number (from 0001 to 9999) the specific person number will be continuous for a Zonal Railway/Firm.
---	---	---	---	--

ISO 9001:2015	Document No:IRST-19-2021	Version No: 7	Effective Date: 01.02.2022
Document Title: Indian Railway Standard Specification for Fusion Welding of Rails By Alumino – Thermic Process Serial No. IRST-19- 2021			

966693/2022/O/o DIRECTOR/QAC/TRACK/RDSO

- c) For para 16.6.4 (a) i.e. for welders/supervisors of Zonal Railways: First two/three initials of the Railway to which the supervisor or welder belongs.

or

For para 16.6.4 (b) i.e. for welders of portion manufacturing firms and welding contractors: Code allotted for the portion manufacturing firms, for whom welders of portion manufacturing firms and welding contractors are approved.

Alphabetic codes allotted to the existing portion manufacturing firms are given below:

ITC =T, Railtech / HTI=H, OTPL=O, SIRIL=S, RMPL=R, , TPP(NR)=N, CDI=C, PTEW=P

In case of welders belonging to the welding contractors, this code will signify the portion manufacturing firm for which the competency certificate of welder is valid.

For example, 010001ECo would indicate a departmental welder/supervisor of East Coast Railway with specific person number 0001. Similarly, 000001T would indicate a welder/supervisor with specific person no. 0001 of portion manufacturer whose code is 'T' i.e. ITC. 020001H would indicate a welder, belonging to welding contractor whose code is 02, having specific person number of 0001 and having competency for welding with portion/technique of portion manufacturing firm with code 'H'.

The Organization issuing competency certificates shall ensure that there is no duplication of the Identification Code Number.

A Bi-annual list of firm's welders having valid competency certificates will be uploaded on RDSO web site. Details of approved AT welders may be seen on website [www.rdso.indianrailways.gov.in](http://www.rdso.indianrailways.gov.in) under button activity of Metallurgical & Chemical Directorate. Copy of Welder's competency certificate of the firm will be uploaded on TMS by Track Design Directorate.

Zonal Railways shall constantly update and maintain the list of supervisors and welders along with their identification code number.

## PART D: ACCEPTANCE TEST OF JOINTS WELDED AT SITE

### 17.0 EXECUTION OF WELDS AT SITE

- 17.1 Alumino - Thermic welding of rails shall be executed at site only by certified welder having valid competency certificate. For welding supervisor's competency

ALOK NATH GUPTA Digitally signed by ALOK NATH GUPTA Date: 2022.02.05 13:44:26 +05'30'	Jaina Ram Meena Digitally signed by Jaina Ram Meena Date: 2022.02.05 13:28:17 +05'30'	SACHIN VERMA Digitally signed by SACHIN VERMA Date: 2022.02.06 18:01:44 +05'30'	Printed:
Prepared By: SSE/Track	Checked By: DD/Track/W	Issued By: DST-5	Page 27 of 63

certificates shall be issued by TPP, Lucknow/ Thermit Welding Centre (TWC), Vijayawada (See Part ‘C-Para 16.2’).

**17.2** All Alumino – thermic welding work shall be executed with the use of weld trimmer and profile grinder. Additionally, rail tensors shall be used wherever work is done on long welded rails.

**17.3** In case, AT welding is carried out by the firm’s welder, quality of AT weld shall be ensured by the firm’s welder and role of welding supervisor (Railway official) is limited to arrangement of traffic block. However, in case, AT welding is carried out by the departmental AT welder, then, both supervisor and welder will be responsible for quality of AT welding.

Note: In case of welding of old rails dispensations for not using weld trimmers and profile grinder shall be obtained from Chief Engineer.

**18.0 ACCEPTANCE TESTS**

**18.1 Visual examination**

All the welded joints shall be cleaned and examined carefully to detect any visible defect like cracks, blow holes, shrinkage, mismatch, surface finish (smooth surface finish required) etc. Any joint which shows visible defect shall be declared defective.

The bottom of the joint shall be checked by feeling with fingers as well as inspected with the help of a mirror for presence of `fins` at the parting line of the mould. If fin is observed in any joint, the joint shall be declared defective.”

**18.2 Joint Geometry**

All the finished welded joints shall be checked to ensure that the joint geometry is within the following tolerances: -

i	Vertical misalignment	+1.0mm -0.0mm	(Measured at the end of 1m straight edge) (Fig.8 (a))
ii	Lateral misalignment	±0.5mm	(Measured at the centre of 1m straight edge) (Fig. 8 (b))
iii	Head finishing on sides	±0.3mm	On gauge side (Measured at the centre of 10cm straight edge (Fig. 8 (c))
iv	Finishing top table surface	+0.4mm -0.0mm	(Measured at the end of 10cm straight edge) (Fig. 8 (d))

**Note:** Dispensation for joint geometry, in case of old rails may be permitted by Chief Engineer. The details of geometry of each joint shall be jointly signed by the firm’s and railway’s representative and kept as a record. Any joint found not conforming to the above stipulations shall be cut and rewelded, free of cost, by the firm.

**18.3 Ultrasonic testing**

Ultrasonic test on welded joints shall be carried out by the Zonal Railway as per procedure laid down for Ultrasonic testing of AT Welds in ‘Manual for Ultrasonic testing of rails & welds’ Revised, 2012” along with its latest revision and updated correction slips, issued by RDSO, Lucknow. In case, the weld is in DFW(O) or DFW (R) category in the ultrasonic examination, the joint shall be considered as defective.

This testing shall be completed as early as possible after welding but in any case not later than 30 days. All the joints which are found to be defective shall be cut and re-welded by the firm at its own cost.

Where one bad joint is required to be replaced by two new joints, the entire cost of both the joints shall be borne by the firm. Such re-welded joints shall also be tested ultrasonically and if found defective, shall again be cut and re-welded free of cost. However, cumulative number of AT welds defective in ultrasonic testing and in other criteria shall be limited to provisions as per clause 19.1.

For upgraded AT welding techniques approved in terms of Part E of IRS T-19: 2020, cumulative number of failed AT welds in ultrasonic testing and in other criteria shall be limited to as per clause 19.1.1.

**18.3.1 Defective/ Fractured joints:**

In case, cumulative number of AT welds failed in criteria given in clause 19.1/19.1.1 exceeds stipulated percentage in respective clauses, following action shall be taken:

- i) Action as per contract conditions be initiated.
- ii) Railway shall be at liberty to suspend further welding.
- iii) The details of welds executed against a particular contract, % defective /fractured welds against total no. of welds executed be compiled as per the following format:

S. No.	Name of firm / welders	Total no. of welds for which contract was awarded (Rail section wise)	No. of welds executed against a particular contract	No. of fractured welds and their % w.r.t. (3)	No. of USFD welds and their % w.r.t. (3)	Total % defective /fractured [(5)+(6)]
(1)	(2)	(3)	(4)	(5)	(6)	(7)

ALOK NATH GUPTA <small>Digitally signed by ALOK NATH GUPTA Date: 2022.02.05 13:44:26 +05'30'</small>	Jaina Ram Meena <small>digitally signed by jaina ram meena Date: 2022.02.05 13:44:26 +05'30'</small>	SACHIN VERMA <small>Digitally signed by SACHIN VERMA Date: 2022.02.05 18:01:44 +05'30'</small>	Printed:
Prepared By: SSE/Track	Checked By: DD/Track/W	Issued By: DST-5	Page 29 of 63

- iv) All defective joints shall be broken with the help of Jim crow in presence of firm’s representative and a joint report be prepared. Defects observed on fractured faces shall be recorded in form of photograph/ sketch.
- v) Sectional DEN/Sr. DEN shall carry out investigation/analysis for all in track fractured joints and joints broken as per iv) above. Information shall be compiled in the format indicated below:

S. No	Km / Post	Rail section/ UTS	Year of rolling	Joint no. (marking punched on the weld)	USFD defective joints (in Initial acceptance testing)			Fractured joints Defects observed on fracture faces (if any)	Remarks
					Probe *	Peak pattern (travel & peak height) *	Defects observed (if any) on fractured faces of defective AT welds (broken with the help of Jim crow)		
(1)	(2)	(3)	(4)	(5)	(6)	(7)	(8)	(9)	(10)

\* If defective in flange testing, supporting calculation be also enclosed in terms of Note in Chapter 8 of ‘Manual for Ultrasonic testing of rails and welds, Revised 2012’.

- vi) The investigation report prepared by sectional DEN/ Sr. DEN be sent to Executive Director/Track-II, RDSO, Lucknow through Chief Track Engineer for appraisal and suggesting further action.
- vii) The defective joints taken out of track and fractured joints be preserved for undertaking investigation by RDSO, if required.

**18.4 Sample Test Joint:**

One out of every 100 joints welded per batch shall be selected at random by the purchaser or by the inspecting officer within one month of welding and subjected to hardness and transverse load test as per clause 4.4.2 and 4.4.3 of this specification respectively and the joint shall comply with the provisions laid down therein.

**18.4.1** In the event of the failure of sample test joint in any of the requirements of this specification, the Railway will be at liberty to suspend further welding. However, two more randomly selected joints from the same lot of 100 joints shall be subjected to re-tests as per clause 4.4. Both the joints shall clear all the tests. If the report is also not satisfactory, further welding of joints shall be suspended until the firm has examined the welding technique and satisfies the requirements of Clause 4 by

welding one test joint. The clearance for re-commencement of welding shall be given by RDSO.

## 19.0 GUARANTEE

**19.1** Rail joints welded by a firm shall be guaranteed against failure which includes failures in execution, acceptance, acceptance & regular ultrasonic testing and during service up to 2 years from the date of welding the joints in track or from the date such welded joints made 'on cess' and inserted in the track are open to traffic. Any such welded joints which fail in the criteria given above within the guarantee period shall be re-welded free of cost by firm as per stipulations of clause 18.3.

However, cumulative number of failed AT welds including rewelded joints in criteria given above up to 2 years, shall not exceed 2% of the total quantity of joints in a particular contract. A penalty of three times the rate of supply and execution of joints shall be payable by the firm for each joint failing in above criteria.

**19.1.1** For upgraded AT welding techniques approved in terms of Part E of IRS T-19: 2021, the joints welded by a firm shall be guaranteed against failure which includes failures in execution, acceptance, acceptance & regular ultrasonic testing and during service up to 120 GMT or 3 years whichever is earlier, from the date of welding the joints in track or from the date such welded joints made 'on cess' and inserted in the track are open to traffic. Any such welded joints which fail in the criteria given above within the guarantee period shall be re-welded free of cost by firm as per stipulations of clause 18.3.

However, cumulative number of failed AT welds including rewelded joints of upgraded AT welding technique in criteria given above up to 120GMT or 3 years whichever is earlier, shall not exceed 0.4% of the total quantity of joints in a particular contract. A penalty of three times the rate of supply and execution of joints shall be payable by the firm for each joint failing in above criteria.

**19.2** In case of failure of sample test joints (refer Clause 18.4), the period of guarantee for 100 joints represented by the sample joint shall be extended for a further period of one year. In case of failure of joints or joints exhibiting signs of failure by cracking within extended period of guarantee, the joints shall be re-welded free of cost by the supplier as per stipulations of clause 18.3.

**19.3** The welded joints with the extended period of guarantee shall be punch marked 'X' on the right of markings for month/year in addition to the markings prescribed in Clause 20. Such marked joints shall be kept under careful observation by the purchaser.

<b>ALOK NATH GUPTA</b> <small>Digitally signed by ALOK NATH GUPTA Date: 2022.02.05 12:44:26 +05'30'</small>	<b>Jaina Ram Meena</b> <small>digitally signed by jaina ram meena Date: 2022.02.05 12:29:57 +05'30'</small>	<b>SACHIN VERMA</b> <small>Digitally signed by SACHIN VERMA Date: 2022.02.06 18:01:44 +05'30'</small>	Printed: Page 31 of 63
Prepared By: SSE/Track	Checked By: DD/Track/W	Issued By: DST-5	

**20.0 MARKING**

Each joint shall have a distinctive mark indicating month, year of welding, firm and welder identification code number (as appearing on his competency certificate) at non-gauge face side of AT weld on head as given below:

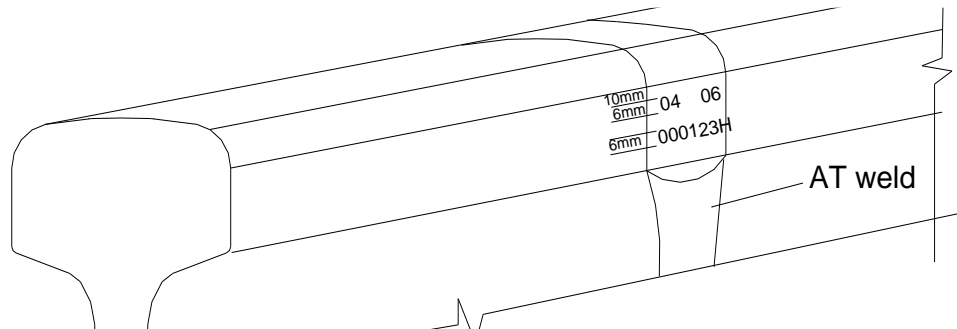

**Figure 3 : Location of marking on non-gauge face of welds**

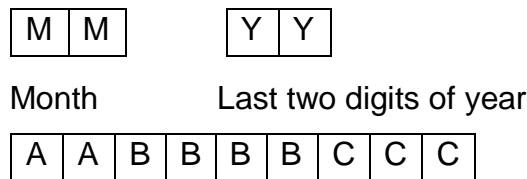

**(Identification code)**

where,

A	A
---	---

 Code number for the agency to which the welder belongs i.e.  
 00 for AT portion manufacturing firms  
 01 for departmental welders  
 02-99 for welders of welding contractors. The codes shall be allotted for different contractual agencies undertaking AT welding of rails (other than portion manufacturers)

B	B	B	B
---	---	---	---

 – Specific person number (from 0001 to 9999) The specific person number will be continuous for a Zonal Railway/Firm.

C – For welders of Zonal Railways: First two/three initials of the Railway to which the supervisor or welder belongs

or

For welders of portion manufacturing firms and welding contractors: Code allotted for the portion manufacturing firms, for whom welders of portion manufacturing firms and welding contractors are approved.



Alphabetic codes allotted to the existing portion manufacturing firms are given below:

ITC =T, Railtech/ HTI=H, OTPL=O, SIRIL=S, RMPL=R, TPP(NR)=N, CDI=C, PTEW=P, ORA=A

In case of welders belonging to the welding contractors, this code will signify the portion manufacturing firm for which the competency certificate of welder is valid.

The marking shall be embossed on the non gauge face side of AT weld by punching after finishing of the weld in letters/digits of 6mm height located as indicated in Figure 3 above.

In addition to this, alphabetic code allotted to portion manufacturing firm as per above e.g. T, H, N etc. and year of manufacture (last two digits of the year) shall also be embossed on the mould to appear on web collar.

For example, 010001ECo would indicate a departmental welder/supervisor of East Coast Railway with specific person number 0001. Similarly, 000001T would indicate a welder/supervisor with specific person no. 0001 of portion manufacturer whose code is 'T' i.e. ITC. 020001H would indicate a welder, belonging to welding contractor whose code is 02, having specific person number of 0001 and having competency for welding with portion/technique of portion manufacturing firm with code 'H'."

**21.0 WITHDRAWAL OF APPROVAL OF PORTION MANUFACTURER/ WELDING SUPERVISOR/ WELDER FROM APPROVED LIST**

The approving authority can delete the name of any Portion Manufacturer/Welding Supervisor/Welder from the approved list based on complaints regarding the performance.

Zonal Railways shall investigate and inform RDSO regarding the poor performance of the AT welder, if the total numbers of defective/ fractured welds executed by him exceeds 2%. The competency certificate of AT welder may be withdrawn and his name will be removed from the list of approved welders based on report and recommendation of Zonal Railway.

ISO 9001:2015	Document No:IRST-19-2021	Version No: 7	Effective Date: 01.02.2022
Document Title: Indian Railway Standard Specification for Fusion Welding of Rails By Alumino – Thermic Process Serial No. IRST-19- 2021			

966693/2022/O/o DIRECTOR/QAC/TRACK/RDSO

## 22.0 PART E: APPROVAL OF PORTION MANUFACTURERS FOR UPGRADED A.T. WELDING TECHNOLOGY

**22.1** The approval of Portion Manufacturer for upgraded AT welding technology, under this part shall cover firms falling in following categories and having/ intending to have in India manufacturing facilities for portion and consumables and other infrastructural facilities for training of welders and execution of welds. However, the firm shall have manufacturing facilities for portion & consumables and other infrastructural facilities for training of welders & execution of welds as laid down in 'Item specific guidelines for vendor approval/extension of approval for manufacturing of AT portion and execution of AT joints (Documents no. TDG 0017,with latest Revision)' with latest correction slips in India before applying for registration of their firm for approval for manufacturing of AT portion and execution of AT welds of rail.

### 22.1.1 Category-I Global Firms

**22.1.1.1** The firm shall be manufacturer of portions and consumables such as moulds, crucible, luting paste, auto thimble etc.

**22.1.1.2** The firm must have a proven international technology, which shall mean that at least 5000 welds must have been executed using the technique on high speed passenger carrying lines (160km/hour and higher) or lines carrying axle loads of 25tonnes and higher in at least three countries. Certificates in this regard from relevant railway systems shall be furnished.

**22.1.1.3** The firm shall have produced and supplied at least 1 million welding kits for various alumino-thermic welding processes.

**22.1.1.4** The firm shall possess sound technical and R&D credentials.

**22.1.1.5** The firm shall possess necessary infrastructure namely manpower and machinery for undertaking execution of welds on Indian Railways.

**22.1.1.6** A certificate regarding having complied less than 0.4% failure rate during execution, acceptance, acceptance ultrasonic testing and in service up to 120GMT or 3 years whichever is earlier (this includes weld failures and welds declared defective during regular ultrasonic testing up to three years of installation) from Railway system satisfying speed /axle load criteria given at Para 22.1.1.2, is to be furnished.

### 22.1.2 Category-II

**22.1.2.1** Indian firms, having technical collaboration with global firms fulfilling requirements mentioned for Category-I in Para 22.1.1 for manufacturing of portions and

<b>ALOK NATH GUPTA</b> Digitally signed by ALOK NATH GUPTA Date: 2022.02.25 13:44:26 +05'30'	<b>Jaina Ram Meena</b> Digitally signed by Jaina Ram Meena Date: 2022.02.25 13:44:26 +05'30'	<b>SACHIN VERMA</b> Digitally signed by SACHIN VERMA Date: 2022.02.06 18:01:44 +05'30'	Printed:
Prepared By: SSE/Track	Checked By: DD/Track/W	Issued By: DST-5	Page 34 of 63

consumables, training of welders and execution of welds subject to the condition that the global partner firm categorically gives undertaking regarding sharing of responsibility towards maintaining–required standards of consumables, welders and welds and fulfillment of service performance requirements of welds with their Indian counterpart.

**22.1.3 Category-III**

**22.1.3.1** Firms not meeting requirements of Category I & Category II above, but having experience of manufacturing, supplying and executing at least ten thousand AT welds on track having speed of 100Kmph or more and axle load of 20.32t or more. Approval to such firms shall be on provisional basis for three years with condition that such firms shall be eligible to get order up to maximum 25% and 40% of tendered quantity, if the offer is received from single firm and more than one firm respectively, besides fulfilling other provisions contained in this Part.

**22.2** “Approving Authority” shall be Director General, Research Designs & Standards Organisation, Ministry of Railways, Manak Nagar, Lucknow – 226011 or his representative.

**22.3** The approval of ‘Portion manufacturer’ shall be given as per clause Part B of this specification.

**22.4** The welding techniques shall be suitable for axle loads of 25t (freight services at maximum speed of 100 kmph)/18.8t (passenger services at maximum speed of 150 kmph). Operation of 32.5t axle load freight trains and passenger trains up to 200kmph is also contemplated. Separate techniques can be offered suiting to various combinations of axle loads and speeds.

**22.5 PROCEDURE FOR APPROVAL OF PORTION MANUFACTURERS:**

**22.5.1** The application for approval shall be submitted by the firm as per “On-line vendor registration system” for approval of their firm for manufacturing of AT portions and welding of rail joints.

**22.5.2** The documents to be submitted by firm in support of credentials shall be as per the requirement of the category in which firm has offered for approval. Further clearance will be given to firm only after the credentials are fulfilled. If in case, documents are found incorrect at any stage of approval/ after approval, the approval process shall be discontinued/ approval shall be withdrawn.

- 22.5.3** After credentials are found satisfactory based on records submitted by firm, the applications shall be submitted by firm as per procedure given in Vendor Registration Guidelines available on RDSO website.
- 22.5.4** The payment shall be made by means specified in 'Vendor Registration Guidelines available on RDSO website.
- 22.5.5** If the information submitted by the applicant is prima facie found to be satisfactory, the approving authority shall inspect the premises of the applicant for assessment.
- 22.5.6** If the assessment is satisfactory, firm shall be advised to offer their welding technology along with complete details of the process and process parameters e.g. rail section/chemistry, type of preheating, type of crucible used, type of mould, tapping system, weld metal dimensions, weld metal chemistry, fusion width, extent of HAZ, hardness profile etc. After receipt of process details and range of various parameters, firm shall be advised for execution of joints for lab evaluation. During this process the parameters advised by firm shall be verified. In case there is variation, the parameter values obtained during lab evaluation shall be treated as final and frozen for reference.

**22.6 TESTS AND TRIALS FOR APPROVAL OF 'PORTION MANUFACTURERS**

- 22.6.1** The Portion Manufacturer shall manufacture a batch of minimum 50 portions in presence of RDSO representatives at his own cost. Sample portions required for execution of AT welds for lab tests including fatigue test, shall be drawn at random from above mentioned batch by the Approving Authority and their weight be recorded. The weight of the portions shall be within  $\pm 0.25\%$  of the average weight.
- 22.6.2** Following laboratory tests shall be carried out at the manufacturer's works premises or at a laboratory mutually agreed upon between the manufacturer and the approving authority.
  - 22.6.2.1** Twelve test weld joints shall be made as per technique offered by the manufacturer. For preparing these joints, two new rail pieces of same section and grade, each minimum 650 mm long shall be used. The rail table and size of rail head shall be finished. The weld joints shall be subjected to following tests.
    - 22.6.2.1.1** Ultrasonic test on test weld joints shall be carried out as per procedure laid down for Ultrasonic testing of AT Welds in 'Manual for Ultrasonic testing of rails & welds' Revised, 2012" or its latest revision along with updated correction slips, issued by RDSO, Lucknow. Welds shall not have defects. In case, the weld is in DFW(O) or DFW (R) category in the ultrasonic examination, the joint shall be considered as defective.

<b>ALOK NATH GUPTA</b> <small>Digitally signed by ALOK NATH GUPTA Date: 2022.02.05 13:44:26 +05'30'</small>	<b>Jaina Ram Meena</b> <small>digitally signed by jaina ram meena Date: 2022.02.05 13:23:57 +05'30'</small>	<b>SACHIN VERMA</b> <small>Digitally signed by SACHIN VERMA Date: 2022.02.06 18:01:44 +05'30'</small>	Printed: Page 36 of 63
Prepared By: SSE/Track	Checked By: DD/Track/W	Issued By: DST-5	

**22.6.2.1.2** Brinell hardness test on all the joints as per clause 4.4.2. The hardness profile obtained shall be recorded. Hardness profile other than Clause 4.4.2 may be permitted, provided-

- a) Firm shall provide proof of present use of proposed hardness profiles on railway network having mixed traffic elsewhere in the globe along with certificate of satisfactory performance from user Railways.
- b) Firm shall give undertaking that wear on the welds up to traffic equivalent to the half life of rails shall remain controlled to the extent so as to not require replacement of weld on this account.

**22.6.2.1.3** Transverse load and deflection test as per clause 4.4.3 on six randomly selected joints..

**22.6.2.1.4** Weld metal chemistry test shall be conducted on six randomly selected test joints on the rail weld running surface at 10mm away from weld transverse axis and composition of steel shall be determined for carbon, manganese, silicon, sulphur, phosphorous, vanadium, molybdenum, aluminium & chromium etc.

**22.6.2.1.5** Macro examination on deep etched longitudinal section, across the weld on the remaining six joints shall be conducted. This examination shall not reveal any lack of fusion or cracks. Other welding defects, e.g. porosity, inclusions etc. in the weld area in longitudinal section shall be recorded in % of weld area. The size of any individual defect shall also be recorded. For confirming any defect found in macro examination, magnetic crack detection test may also be carried out.

**22.6.2.1.6** Microscopic examination: Samples for microscopic examination shall be taken and prepared in accordance with Annexure- 1. The structure of the fusion zone and visible heat affected zone shall conform to that defined by the supplier at x 100 magnification.

**22.6.2.1.7** Any other specific parameter having bearing on performance of welds in service shall also be specifically brought out by the firm along with methodology for measurement/assessment of the same. Such parameters shall be measured and recorded.

**22.6.3 Fatigue Test**

This shall be undertaken as per Para 13 of Part B of specification.

**22.6.4 Provisional Approval**

**22.6.4.1** In case of results of above tests are satisfactory, the firm shall be granted provisional approval for a period of 3 years for execution of welds on the revenue track.

ALOK NATH GUPTA <small>Digitally signed by ALOK NATH GUPTA Date: 2022.02.05 13:46:26 +05'30'</small>	Jaina Ram Meena <small>digitally signed by jaina ram meena Date: 2022.02.05 13:29:57 +05'30'</small>	SACHIN VERMA <small>Digitally signed by SACHIN VERMA Date: 2022.02.06 18:01:44 +05'30'</small>	Printed:  Page 37 of 63
Prepared By: SSE/Track	Checked By: DD/Track/W	Issued By: DST-5	

## 22.6.5 Field Trial

**22.6.5.1** First 250 joints, executed as part of first contract by the firm using portions of batches duly inspected and passed by RDSO representative, shall be monitored as part of field trial. These joints shall be ultrasonically tested by the Zonal Railway soon after welding and periodically as laid down for Ultrasonic testing of AT Welds in 'Manual for Ultrasonic testing of rails & welds' Revised, 2012" along with its latest revision and updated correction slips. In case, the weld is in DFW(O) or DFW (R) category in the ultrasonic examination, the joint shall be considered as defective. The joints shall exhibit less than 0.4% failure rate during execution, acceptance, acceptance ultrasonic testing and in service up to 120GMT or 3 years whichever is earlier. This includes weld failures and welds declared defective during regular ultrasonic testing up to three years of installation. The data of failure rate will be obtained from concerned CTE of the Railway.

**22.6.5.2** If percentage of defective welds including failures exceeds 0.4% at any stage, the trial shall be discontinued considering the technique to be unsatisfactory. The defective welds, shall be removed from the track, cut and re-welded by the manufacturer at his own expense.

**22.7** The approving authority shall have free access to the premises of the portion manufacturer at all reasonable times. The portion manufacturer shall furnish all the technical data to the approving authority as and when call for.

**22.8** A Bank Guarantee for an amount equal to 30% of the cost of contract, apart from the usual performance guarantee, will have to be submitted by the firm as guarantee against fulfillment of guaranteed service life by the executed welds within one month from the award of the contract. This bank guarantee will be released after successful service life of 120GMT or completion of three years, by the executed welds, whichever is earlier.

**22.9** Acceptance test of joints welded at site shall be as per Part-D of this specification.

**22.10** The firm will be required to provide training to Indian Railway welders in India free of cost for undertaking emergent repair welding on Indian Railway network using approved AT welding technique of the firm as per requirement. A certificate shall be issued by the firm to the successful welders. These trained welders shall be then required to obtain competency certificates from TPP/Lucknow or TWC/Vijayawada for execution of welds on Indian Railway track using firm's approved technique.

ALOK NATH GUPTA Digitally signed by ALOK NATH GUPTA Date: 2022.02.05 13:44:26 +05'30'	Jaina Ram Meena Digitally signed by Jaina Ram Meena Date: 2022.02.05 13:29:57 +05'30'	SACHIN VERMA Digitally signed by SACHIN VERMA Date: 2022.02.06 18:01:44 +05'30'	Printed:
Prepared By: SSE/Track	Checked By: DD/Track/W	Issued By: DST-5	Page 38 of 63

**ANNEXURE-1**

**PROCEDURE FOR MICROSCOPIC EXAMINATION OF THE VISIBLE HEAT AFFECTED ZONE AND FUSION ZONE OF WELDS**

Samples for microscopic examination shall be taken in accordance with Figure given below. The samples shall be prepared and etched in 2% Nital.

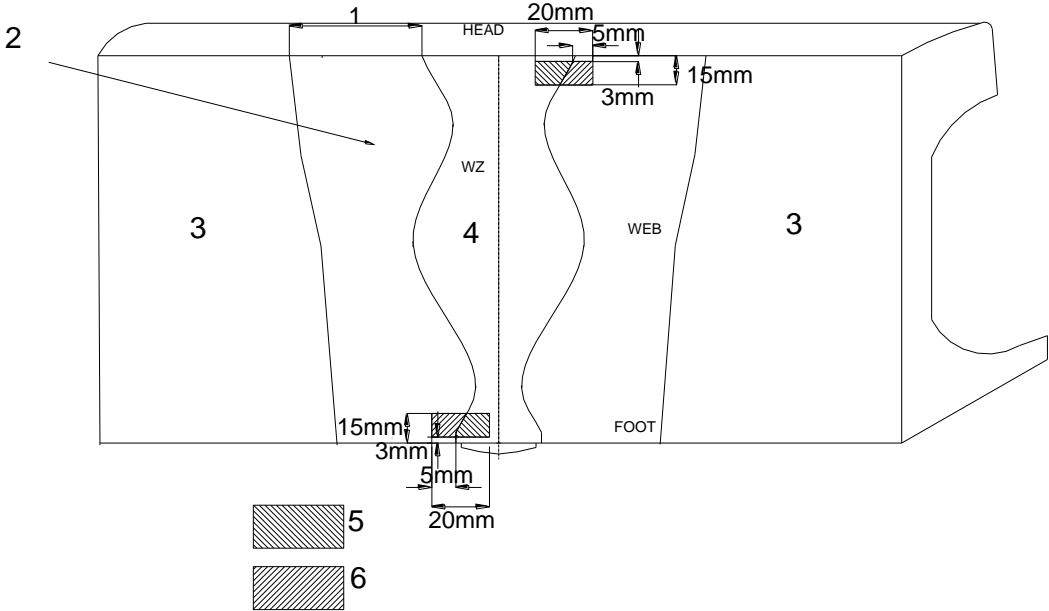

**Figure 4-Scheme for taking samples for microscopic examination**

**Key**

1. Width of the visible heat affected zone to be measured at the weld longitudinal centre line of the running surface.
2. Visible heat affected zone.
3. Unaffected parent rail.
4. Weld fusion zone.
5. Area of fusion zone to be examined microscopically.
6. Area of visible heat affected zone to be examined microscopically.

ALOK NATH GUPTA <small>Digitally signed by ALOK NATH GUPTA Date: 2022.02.05 13:44:26 +05'30'</small>	Jaina Ram Meena <small>digitally signed by jaina ram meena Date: 2022.02.05 13:22:57 +05'30'</small>	SACHIN VERMA <small>Digitally signed by SACHIN VERMA Date: 2022.02.06 18:01:44 +05'30'</small>	Printed: Page 39 of 63
Prepared By: SSE/Track	Checked By: DD/Track/W	Issued By: DST-5	

**ANNEXURE -2**

**SPECIFICATION OF 3-PIECES PRE-FABRICATED MOULD MANUFACTURED BY AT PORTION MANUFACTURERS FOR USE DURING AT WELDING OF RAILS AS PER IRST-19-2021**

**0.0 FOREWARD:**

**0.1** Indian Railways have introduced Alumino-thermic welding of rail joints since five decades. The mould required for accommodating molten thermit steel around the joint to make a bond between the rails, was earlier made of green sand. Due to introduction of short preheating process in eighties, the moulding practice was switched over to prefabricated sodium silicate dry sand mould or Pre-Fabricated Mould (PFM) with an intention to minimize the welding time and bring improvement in quality of joint.

Earlier 2 pieces PFM were used in Indian Railways. The main drawback of 2 pieces PFM was the appearance of Fins at the bottom of AT joints. To overcome this AT welding defect a new 3 pieces PFM has been developed as per the figure given in Fig.1. Third bottom piece of one set-3 pieces PFM during AT welding shall not result the bottom fin. However, care must be taken during fitment of 3 pieces PFM so that the two-parting line at the rail flange edges are avoided.

**1.0 SCOPE:**

This standard includes basic requirements & quality control of raw materials required for moulding, manufacture of moulds, quality control during manufacture and of finished product and packing conditions for use during A.T. welding of rails of different sections as per IRS-T-19- 2020. This standard shall be applicable for A.T. Portion manufacturers.

**2.0 REFERENCES:**

While preparing this standard following specifications have been referred to:

- IRS-T-19- 2020 IRS Specification for fusion welding of rails by Alumino-thermic process
- IS:1918-66 (Reaffirmed 2003) Method of physical tests for foundry sands.
- IS:1987-2002 Specification for High Silica sand for use in foundries.
- IS:6773-78 (Reaffirmed 2003) Specification for Sodium Silicate for use in foundries.
- IS:10091-81 (Reaffirmed 2003) Specification for Iron Oxide Powder for use in foundries.
- IS:2-1960 (Reaffirmed 2006) Rules for rounding off numerical values.
- IS:12446-2007 Specification for Bentonite for use in foundries.
- IS:10033-1992 (Reaffirmed 2003) Zircon and Graphite based core and mould washes
- IS:307-1966 (Reaffirmed 2006) Carbon-di-oxide gas of commercial grade
- IS:9738-2003 Polyethylene Bags for General Purposes
- IS: 11099-1984 (Reaffirmed 2005) Universal Sand testing machines.

<b>ALOK NATH GUPTA</b> <small>Digitally signed by ALOK NATH GUPTA Date: 2022.02.06 13:44:26 +05'30'</small>	<b>Jaina Ram Meena</b> <small>digitally signed by jaina ram meena Date: 2022.02.06 13:20:57 +05'30'</small>	<b>SACHIN VERMA</b> <small>Digitally signed by SACHIN VERMA Date: 2022.02.06 18:01:44 +05'30'</small>	Printed: Page 40 of 63
Prepared By: SSE/Track	Checked By: DD/Track/W	Issued By: DST-5	



The latest publication of above specification shall be consulted by the users.

### 3.0 ARRANGEMENT OF 3 PIECES PFM

One set of PFM shall comprise 3 pieces of moulds (2 Parts are in identical shape & sizes placed side by side and 3<sup>rd</sup> part is placed at the bottom) as per following sketch:

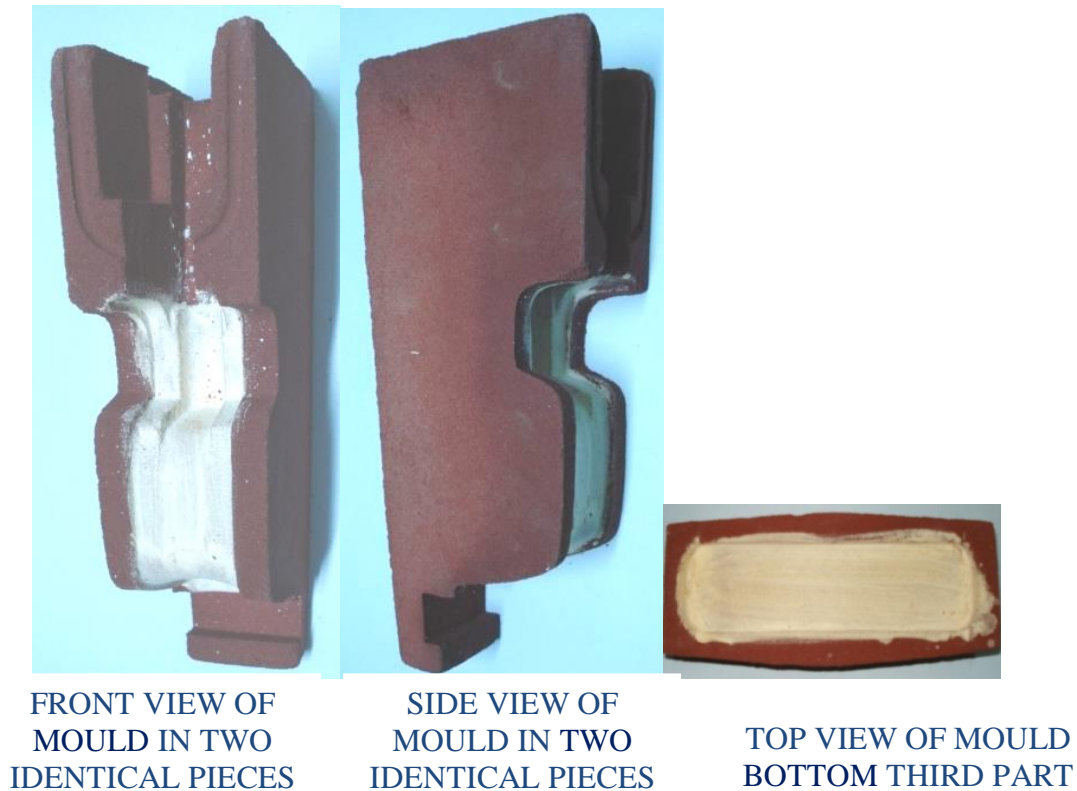

**Fig-5** (Figure is indicative only)

### 4.0 RAW MATERIALS:

#### 4.1 HIGH SILICA SAND:

**4.1.1** The silica sand shall be of appropriate grade in respect of chemical composition & grain fineness as per IS: 1987-2002. The grade used as per requirement of firm shall be indicated in QAP of firm. The grain shape shall be mostly of sub angular to rounded shape.

**4.1.2** The manufacturer shall keep record/ inspection certificate of high silica sand, being used in the production as per IS-1987-2002 with proper traceability. The manufacturer shall also carry out its own inspection check on the Silica sand and proper record shall be maintained with traceability.

ALOK NATH GUPTA <small>Digitally signed by ALOK NATH GUPTA Date: 2022.02.05 12:44:26 +05'30'</small>	Jaina Ram Meena <small>digitally signed by jaina ram meena Date: 2022.02.05 13:20:57 +05'30'</small>	SACHIN VERMA <small>Digitally signed by SACHIN VERMA Date: 2022.02.06 18:01:44 +05'30'</small>	Printed:
Prepared By: SSE/Track	Checked By: DD/Track/W	Issued By: DST-5	Page 41 of 63

**4.2 SODIUM SILICATE:**

**4.2.1** Sodium silicate used as a binding agent for pre-fabricated mould shall be of appropriate grade as per IS: 6773-1978 (Reaffirmed 2003). The grade used as per requirement of firm shall be indicated in QAP of firm.

**4.2.2** The manufacturer shall keep record/inspection certificate of sodium silicate, being used in the production as per IS: 6773-1978 (Reaffirmed-2003) with proper traceability. The manufacturer shall also have its own inspection check on sodium silicate batch wise as per Appendix-I and proper record shall be maintained with traceability.

**4.3 IRON OXIDE:**

**4.3.1** Iron oxide is added to the sand mixture to increase the hot strength of the mould. The iron oxide shall be free from clay and in powder form. Iron oxide to IS: 10091-81 (Reaffirmed-2003) shall be used as Iron Oxide ingredient.

**4.3.2** The manufacturer shall keep record/inspection certificate as per IS-10091-1981 (Reaffirmed-2003) with proper traceability of Iron oxide, being used in the production

**4.4 CARBON DI-OXIDE GAS:**

Carbon-di-oxide gas shall be of commercial grade to IS: 307-66 (Reaffirmed 2006). The manufacturer shall keep record of Carbon-di-oxide gas, being used in the production as per IS-307-66 (Reaffirmed 2006) with proper traceability.

**4.5 MOULD WASH:**

**4.5.1** To achieve good finish of the weld surface, mould wash shall be used. It shall be alcohol base Zircon wash Gr. ZA to IS: 10033-92 (Reaffirmed 2003) (See Appendix-II).

**4.5.2** The manufacturer shall keep record/inspection certificate of mould wash being used in the production as per IS-10033-92 (Reaffirmed 2003) with proper traceability. The manufacturer shall also have its own inspection check of mould wash batch wise as per Appendix -II and proper record shall be maintained with traceability.

**5.0 PRODUCT CHARACTERSTICS:**

**5.1** The mould shall be manufactured by no-bake, sodium silicate process using detachable pattern and shall be suitable for welding the required rail section.

<b>ALOK NATH GUPTA</b> <small>Digitally signed by ALOK NATH GUPTA Date: 2022.02.05 13:44:26 +05'30'</small>	<b>Jaina Ram Meena</b> <small>digitally signed by jaina ram meena Date: 2022.02.05 13:44:26 +05'30'</small>	<b>SACHIN VERMA</b> <small>Digitally signed by SACHIN VERMA Date: 2022.02.05 18:01:44 +05'30'</small>	Printed: Page 42 of 63
Prepared By: SSE/Track	Checked By: DD/Track/W	Issued By: DST-5	

**5.2** The dimension of the mould shall be such as to give required weld metal geometry of the joint approved by RDSO. The mould shall fit properly with the rail and in the mould shoe.

**5.3** The mould may be suitably reinforced for adequate stiffness and stiffener design & location shall be a part of the drawing.

**6.0 PRODUCT TRACEABILITY:**

The insignia containing firm's code allotted (ITC=T, Railtech/ HTI=H, QTPL=O, SIRIL=S, RMPL=R, CDI=C, TPP(NR)=N, PTEW=P, ORA=A as per AT welding Manual) and year of manufacture shall be embossed in the mould during manufacture for identification.

**7.0 QUALITY CONTROL:**

**7.1** Quality control shall be carried out in two stages:

- a) Inspection during manufacture.
- b) Inspection of the finished mould.

**7.2 INSPECTION DURING MANUFACTURE:**

**7.2.1** Firm shall have a Quality Assurance Plan duly approved by the competent authority.

**7.2.2** Firm shall keep all the records of quality checks of all incoming raw materials as mentioned in Cl. 4.0 of this Annexure-2. The process control activities shall also have necessary inspection record as per the approved QAP.

**7.2.3** The proportion of the ingredients, pressure and time of passing of CO<sub>2</sub> gas shall also be checked.

**7.2.4** The dimensions of the pattern for its conformity to the drawings of approved weld design shall also be checked. All the measuring instruments shall be maintained in functional order.

**7.2.5** Record of important parameters like moisture content, permeability, hardness and compressive strength (As per IS: 11099-1984- Reaffirmed-2005) of test block of 50x50 mm for every batch i.e. Muller/ Mixer batch of production shall be maintained.

ALOK NATH GUPTA <small>Digitally signed by ALOK NATH GUPTA Date: 2022.02.05 13:44:26 +05'30'</small>	Jaina Ram Meena <small>digitally signed by jaina ram meena Date: 2022.02.05 13:29:57 +05'30'</small>	SACHIN VERMA <small>Digitally signed by SACHIN VERMA Date: 2022.02.06 18:01:44 +05'30'</small>	Printed:
Prepared By: SSE/Track	Checked By: DD/Track/W	Issued By: DST-5	Page 43 of 63

**7.3 INSPECTION OF THE FINISHED MOULD:**

**7.3.1** For Inspection of finished mould, the Batch size shall be production of each day subject to maximum of batch size of AT welding portion of firm+5%, which shall be included in QAP of firm.

**7.3.2** The mould shall be sound and it shall not break during transit under normal condition. The name of the test and their frequency, to be carried out on finished mould by the manufacturer at their own and by purchaser or nominated firm shall be as under:

S.No.	Test	Sample size	Remarks
1.	Visual Examination	1% of Batch size rounded off to next higher number	As per para 7.3.3
2.	Dimensional check	2% of Batch size rounded off to next higher number	As per para 7.3.4
3.	Ringing Test	1% of Batch size rounded off to next higher number	As per para 7.3.5
4.	Hardness Test	1% of Batch size rounded off to next higher number	As per para 7.3.6
5.	Internal surface of mould for proper mould wash	1% of Batch size rounded off to next higher number	As per para 7.3.7
6.	Weld metal dimensions	1 per Batch, to be checked along with AT welding Portion inspection.	As per para 7.3.8

The tests shall be carried out at manufacturer's premises. If any test is conducted by outside approved firm, the cost of the test is to be borne by the manufacturer.

**7.3.3 VISUAL EXAMINATION:**

The prefabricated mould shall be checked visually for any visible imperfection, such as surface condition etc.

**7.3.4 DIMENSIONAL CHECK:**

Dimensional check shall be carried out on 2% of the moulds for their conformity to the respective drawing, fitment with rail end and in mould shoe.

The weld profile dimension achieved in AT weld using developed 3 pieces PF mould shall conform to the approved weld profile dimension. Dimension of 3 pieces PF mould as width and depth at respective web, foot and bottom which affect the weld profile dimension of AT weld will be indicated in QAP of firm and the same shall be standardized during approval. The prescribed limit of Weld profile dimensions as shown in Appendix-III shall be as under: -

<p><b>ALOK NATH GUPTA</b> Digitally signed by ALOK NATH GUPTA Date: 2022.02.05 13:44:26 +05'30'</p>	<p><b>Jaina Ram Meena</b> Digitally signed by jaina ram meena Date: 2022.02.08 13:29:57 +05'30'</p>	<p><b>SACHIN VERMA</b> Digitally signed by SACHIN VERMA Date: 2022.02.06 18:01:44 +05'30'</p>	<p>Printed:</p>
<p>Prepared By: SSE/Track</p>	<p>Checked By: DD/Track/W</p>	<p>Issued By: DST-5</p>	<p>Page 44 of 63</p>

S. No.	Location of dimensional check		Range (In mm)
1	Web	W1	± 3
2		D1	± 2
3	Flange Top	W2	± 3
4		D2	± 2
5	Flange Bottom	W3	± 3
6		D3	± 2

**7.3.5 RINGING TEST:**

Ringing Test shall be carried out by using a small and light hammer made of 10 mm steel rod for checking soundness and degree of ramming during manufacture. The mould shall have characteristic ringing sound and shall not break.

**7.3.6 HARDNESS TEST:**

Hardness Test shall be carried out on the plane surface of the mould using a duly calibrated core hardness tester (scratch type). The min. hardness value for a silicate carbon-di-oxide hardened mould shall be 70. The hardness test shall be carried out as per Cl.26 of IS: 1918-66 (Reaffirmed 2003).

**7.3.7 INTERNAL SURFACE OF MOULD FOR PROPER MOULD WASH:**

Surface finish shall be checked on the moulds for uniform and sufficient coatings as per Cl.7.3 of APPENDIX-II.

**7.3.8 WELD METAL DIMENSIONS:**

Dimensional check shall be carried out on the finished rail joints using mould pairs for conformity of the approved weld profile dimension of respective AT portion manufacturer.

**7.3.9** All requisite Testing facilities to Inspecting officials shall be provided by the manufacturer at their own cost. The Inspecting officials shall have free access at manufacturer’s works in working hours to assess the quality of manufacturing process.

**7.3.10** The manufacturer shall provide test results of raw materials and the batches offered for inspection to the Inspecting officials.

**8.0 SHELF LIFE:**

Shelf life of mould shall be 12 months minimum from the date of manufacturing. Retest of One pair of the mould will be carried out after expiry of 12 months to ascertain the soundness of the mould.

<p><b>ALOK NATH GUPTA</b> Digitally signed by ALOK NATH GUPTA Date: 2022.02.05 12:44:26 +05'30'</p>	<p><b>Jaina Ram Meena</b> Digitally signed by Jaina Ram Meena Date: 2022.02.05 12:29:57 +05'30'</p>	<p><b>SACHIN VERMA</b> Digitally signed by SACHIN VERMA Date: 2022.02.06 18:01:44 +05'30'</p>	<p>Printed: Page 45 of 63</p>
Prepared By: SSE/Track	Checked By: DD/Track/W	Issued By: DST-5	

ISO 9001:2015	Document No:IRST-19-2021	Version No: 7	Effective Date: 01.02.2022
Document Title: Indian Railway Standard Specification for Fusion Welding of Rails By Alumino – Thermic Process Serial No. IRST-19- 2021			

966693/2022/O/o DIRECTOR/QAC/TRACK/RDSO

**9.0 PACKING:**

- 9.1** Each pre-fabricated mould shall be individually packed and sealed in polyethylene bags made out of polyethylene conforming to IS: 9738-2003 Grade HM HDPE of 150 micron thickness or as prescribed by IRS-T-19 2020.
- 9.2** A pair of such packed moulds shall again be packed in carton paper boxes confirming to IS: 2771 (Second Revision). Proper sealing shall be done on each carton.
- 9.3** Each carton shall be clearly marked giving manufacturer's name, date of manufacture and rail section, batch number for easy identification.

ALOK NATH GUPTA <small>Digitally signed by ALOK NATH GUPTA Date: 2022.02.05 12:44:26 +05'30'</small>	Jaina Ram Meena <small>digitally signed by jaina ram meena Date: 2022.02.05 12:42:07 +05'30'</small>	SACHIN VERMA <small>Digitally signed by SACHIN VERMA Date: 2022.02.06 18:01:44 +05'30'</small>	Printed:
Prepared By: SSE/Track	Checked By: DD/Track/W	Issued By: DST-5	Page 46 of 63

**ANNEXURE-3**

**SPECIFICATION OF SINGLE SHOT CRUCIBLE MANUFACTURED BY AT PORTION MANUFACTURERS FOR USE DURING AT WELDING OF RAILS AS PER IRST-19- 2021**

**0.0 FOREWARD:**

**0.1** Indian Railways have introduced Alumino-thermic welding of rail joints since five decades. The crucible required for in which the thermit reaction takes place. With the introduction of this crucible it is no more requirement to carry many equipment like heavy long life crucible, fork, stands, ring, crucible cap etc. to the site for conducting the welding. By providing metallic body outside the crucible gives safety against breakage of crucible with a Lid for preventing the molten metal spill out during reaction.

**1.0 SCOPE:**

This standard includes basic requirements & quality control of raw materials required for manufacture of single shot crucible, quality control during manufacture and of finished product and packing conditions for use during A.T. welding of rails of different sections as per IRS-T-19- 2020. This standard shall be applicable for A.T. Portion manufacturers.

**2.0 REFERENCES:**

While preparing this standard following specifications have been referred to:

- IRS-T-19-2020 IRS Specification for fusion welding of rails by Alumino-thermic process
- IS:1918-66 (Reaffirmed 2003) Method of physical tests for foundry sands.
- IS:1987-2002 Specification for High Silica sand for use in foundries.
- IS:6773-78 (Reaffirmed 2003) Specification for Sodium Silicate for use in foundries.
- IS:10091-81 (Reaffirmed 2003) Specification for Iron Oxide Powder for use in foundries.
- IS:2-1960 (Reaffirmed 2006) Rules for rounding off numerical values.
- IS:12446-2007 Specification for Bentonite for use in foundries.
- IS:307-1966 (Reaffirmed 2006) Carbon-di-oxide gas of commercial grade
- IS:9738-2003 Polyethylene Bags for General Purposes
- IS: 11099-1984 (Reaffirmed 2005) Universal Sand testing machines.

The latest publication of above specification shall be consulted by the users.

<b>ALOK NATH GUPTA</b> <small>Digitally signed by ALOK NATH GUPTA Date: 2022.02.05 12:44:26 +05'30'</small>	<b>Jaina Ram Meena</b> <small>digitally signed by jaina ram meena Date: 2022.02.05 12:22:57 +05'30'</small>	<b>SACHIN VERMA</b> <small>Digitally signed by SACHIN VERMA Date: 2022.02.06 18:01:44 +05'30'</small>	<b>Printed:</b> Page 47 of 63
Prepared By: SSE/Track	Checked By: DD/Track/W	Issued By: DST-5	

### 3.0 ARRANGEMENT OF SINGLE SHOT CRUCIBLE

One set of single shot crucible consist of three parts -

- a) Main crucible body where the thermit reaction takes place.
- b) Crucible cap which is placed on top of the crucible during thermit reaction for preventing the molten metal spill out during thermit reaction.
- c) Bucket with handle shall be provided for carrying the Single shot Crucible. Lid of the crucible which is placed on the top is used for sealing the crucible for safe transportation & storage.

This crucible shall be for single use only.

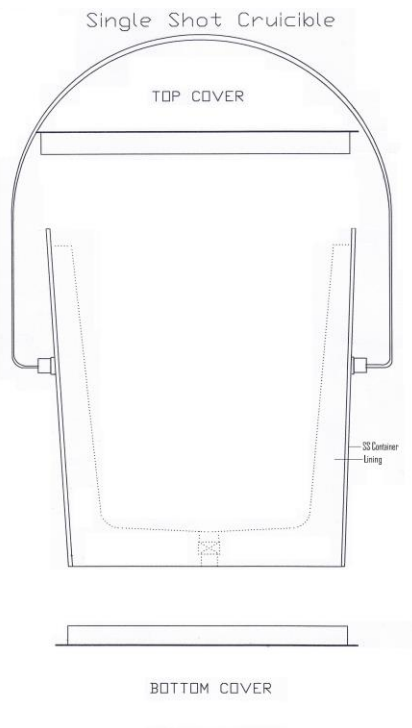

**Single Shot Crucible**

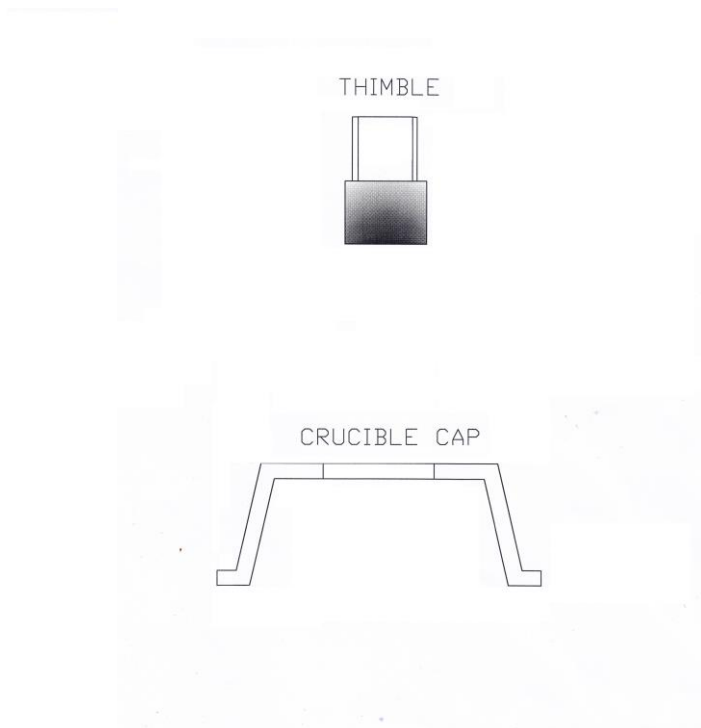

**Crucible cap (X-section at diameter)**



**Lid (X-section at diameter)**

**Fig-6 (Figure is indicative only)**

ALOK NATH GUPTA <small>Digitally signed by ALOK NATH GUPTA Date: 2022.02.25 12:44:26 +05'30'</small>	Jaina Ram Meena <small>digitally signed by jaina ram meena Date: 2022.02.25 12:44:26 +05'30'</small>	SACHIN VERMA <small>Digitally signed by SACHIN VERMA Date: 2022.02.06 18:01:44 +05'30'</small>	Printed: Page 48 of 63
Prepared By: SSE/Track	Checked By: DD/Track/W	Issued By: DST-5	



**4.0 RAW MATERIALS:**

**4.1 HIGH SILICA SAND:**

**4.1.1** The silica sand shall be of appropriate grade in respect of chemical composition & grain fineness as per IS: 1987-2002. The grade used as per requirement of firm shall be indicated in QAP of firm. The grain shape shall be mostly of sub angular to rounded shape.

**4.1.2** The manufacturer shall keep record/ inspection certificate of high silica sand, being used in the production as per IS:1987-2002 with proper traceability. The manufacturer shall also carry out its own inspection check on the Silica sand and proper record shall be maintained with traceability.

**4.2 SODIUM SILICATE:**

**4.2.1** Sodium silicate used as a binding agent for Crucible shall be of appropriate grade as per IS: 6773-1978 (Reaffirmed 2003). The grade used as per requirement of firm shall be indicated in QAP of firm.

**4.2.2** The manufacturer shall keep record/inspection certificate of sodium silicate, being used in the production as per IS: 6773-1978 (Reaffirmed-2003) with proper traceability. The manufacturer shall also have its own inspection check on sodium silicate batch wise as per Appendix-I and proper record shall be maintained with traceability.

**4.3 IRON OXIDE:**

**4.3.1** Iron oxide is added to the sand mixture to increase the hot strength of the Crucible. The iron oxide shall be free from clay and in powder form. Iron oxide to IS: 10091-81 (Reaffirmed-2003) shall be used as Iron Oxide ingredient.

**4.3.2** The manufacturer shall keep record/inspection certificate as per IS: 10091-1981 (Reaffirmed-2003) with proper traceability of Iron oxide, being used in the production.

**4.4 CARBON DI-OXIDE GAS:**

Carbon-di-oxide gas shall be of commercial grade to IS:307-66 (Reaffirmed 2006). The manufacturer shall keep record of Carbon-di-oxide gas, being used in the production as per IS: 307-66 (Reaffirmed 2006) with proper traceability.

ALOK NATH GUPTA <small>Digitally signed by ALOK NATH GUPTA Date: 2022.02.05 12:44:26 +05'30'</small>	Jaina Ram Meena <small>digitally signed by jaina ram meena Date: 2022.02.05 13:20:07 +05'30'</small>	SACHIN VERMA <small>Digitally signed by SACHIN VERMA Date: 2022.02.06 18:01:44 +05'30'</small>	Printed: Page 49 of 63
Prepared By: SSE/Track	Checked By: DD/Track/W	Issued By: DST-5	

#### 4.5 CRUCIBLE CONTAINER OF STEEL SHEET WITH HANDLE:

4.5.1 The container shall be of appropriate thickness and as per approved drawing submitted by the individual manufacturer. It shall be strong enough to protect the Single shot Crucible during transportation.

#### 4.6 OTHER INGREDIENTS - THIMBLE PARTS:

The Crucible shall be fitted with in-built Automatic tapping thimble which allows to flow the liquid steel automatically into the prefabricated mould.

#### 5.0 PRODUCT CHARACTERSTICS:

5.1 The crucible shall be manufactured by no-bake, sodium silicate process using detachable pattern and shall be suitable for thermit welding.

5.2 The dimension of the crucible shall be such as to give required accommodation for taking weld metal reaction.

5.3 The crucible may be suitably inhouse in a steel sheet container for safety of the crucible.

#### 6.0 PRODUCT TRACEABILITY:

The insignia containing firm's code allotted (ITC=T, Railtech/ HTI=H, OTPL=O, SIRIL=S, RMPL=R, IFA=F, CDI=C, TPP(NR)=N, PTEW=P as per AT welding Manual) and year of manufacture shall be Marked in the crucible during manufacture for identification.

#### 7.0 QUALITY CONTROL:

7.1 Quality control shall be carried out in two stages:

- Inspection during manufacture.
- Inspection of the finished crucible.

#### 7.2 INSPECTION DURING MANUFACTURE:

7.2.1 Firm shall have a Quality Assurance Plan duly approved by the competent authority.

7.2.2 Firm shall keep all the records of quality checks of all incoming raw materials as mentioned in Cl. 4.0 of this Annexure-3. The process control activities shall also have necessary inspection record as per the approved QAP.

7.2.3 The proportion of the ingredients, pressure and time of passing of CO<sub>2</sub> gas shall also be checked.

<b>ALOK NATH GUPTA</b> <small>Digitally signed by ALOK NATH GUPTA Date: 2022.02.05 13:46:26 +05'30'</small>	<b>Jaina Ram Meena</b> <small>digitally signed by jaina ram meena Date: 2022.02.05 13:29:57 +05'30'</small>	<b>SACHIN VERMA</b> <small>Digitally signed by SACHIN VERMA Date: 2022.02.06 18:01:44 +05'30'</small>	Printed:
Prepared By: SSE/Track	Checked By: DD/Track/W	Issued By: DST-5	Page 50 of 63

**7.2.4** The dimensions of the pattern for its conformity to the drawings of approved design shall also be checked. All the measuring instruments shall be maintained in functional order.

**7.2.5** Record of important parameters like moisture content, permeability, hardness and compressive strength (As per IS: 11099-1984- Reaffirmed-2005) of test block of 50x50 mm for every batch i.e. Muller/ Mixer batch of production shall be maintained.

**7.3 INSPECTION OF THE FINISHED CRUCIBLE:**

**7.3.1** For Inspection of finished crucible, the Batch size shall be production of each day subject to maximum of batch size of AT welding portion of firm+5%, which shall be included in QAP of firm.

**7.3.2** The crucible shall be sound and it shall not break during transit under normal condition. The name of the test and their frequency, to be carried out on finished crucible by the manufacturer at their own and by purchaser or nominated firm shall be as under:

S.No.	Test	Sample size	Remarks
1.	Visual Examination	1% of Batch size rounded off to next higher number	As per Para 7.3.3 below
2.	Dimensional check	2% of Batch size rounded off to next higher number	As per Para 7.3.4 below

The tests shall be carried out at manufacturer's premises. If any test is conducted by outside approved firm, the cost of the test is to be borne by the manufacturer.

**7.3.3 VISUAL EXAMINATION:**

The prefabricated crucible shall be checked visually for any visible imperfection, such as surface condition, crack, moisture etc.

**7.3.4 DIMENSIONAL CHECK:**

Dimensional check shall be carried out on 2% of the Crucible for their conformity to the respective drawing.

**7.3.5** All requisite Testing facilities to Inspecting officials shall be provided by the manufacturer at their own cost. The Inspecting officials shall have free access at manufacturer's works in working hours to assess the quality of manufacturing process.

**7.3.6** The manufacturer shall provide test results of raw materials and the batches offered for inspection to the Inspecting officials.

ISO 9001:2015	Document No:IRST-19-2021	Version No: 7	Effective Date: 01.02.2022
Document Title: Indian Railway Standard Specification for Fusion Welding of Rails By Alumino – Thermic Process Serial No. IRST-19- 2021			

966693/2022/O/o DIRECTOR/QAC/TRACK/RDSO

**8.0 SHELF LIFE:**

Shelf life of Crucible shall be 12 months minimum from the date of manufacturing. Retest of One Crucible will be carried out after expiry of 12 months to ascertain the soundness of the crucible.

**9.0 PACKING:**

**9.1** Each Crucible shall be individually packed and sealed in polyethylene bags made out of polyethylene conforming to IS: 9738-2003 Grade HM HDPE of 150 micron thickness or as prescribed by IRS-T-19-2020.

**9.2** Such packed Crucible shall again be packed in carton paper boxes confirming to IS: 2771 (Second Revision). Proper sealing shall be done on each carton.

**9.3** Each carton shall be clearly marked giving manufacturer's name, date of manufacture and rail section, batch number for easy identification.

ALOK NATH GUPTA <small>Digitally signed by ALOK NATH GUPTA Date: 2022.02.05 13:44:26 +05'30'</small>	Jaina Ram Meena <small>Digitally signed by Jaina Ram Meena Date: 2022.02.05 13:29:57 +05'30'</small>	SACHIN VERMA <small>Digitally signed by SACHIN VERMA Date: 2022.02.06 16:01:44 +05'30'</small>	Printed:
Prepared By: SSE/Track	Checked By: DD/Track/W	Issued By: DST-5	Page 52 of 63

**ANNEXURE- 4**

**FATIGUE TEST ARRANGEMENT FOR AT WELDS**

Test shall be conducted in four point bending with stress range and Test frequency as specified in the Para 13.3 of this specification.

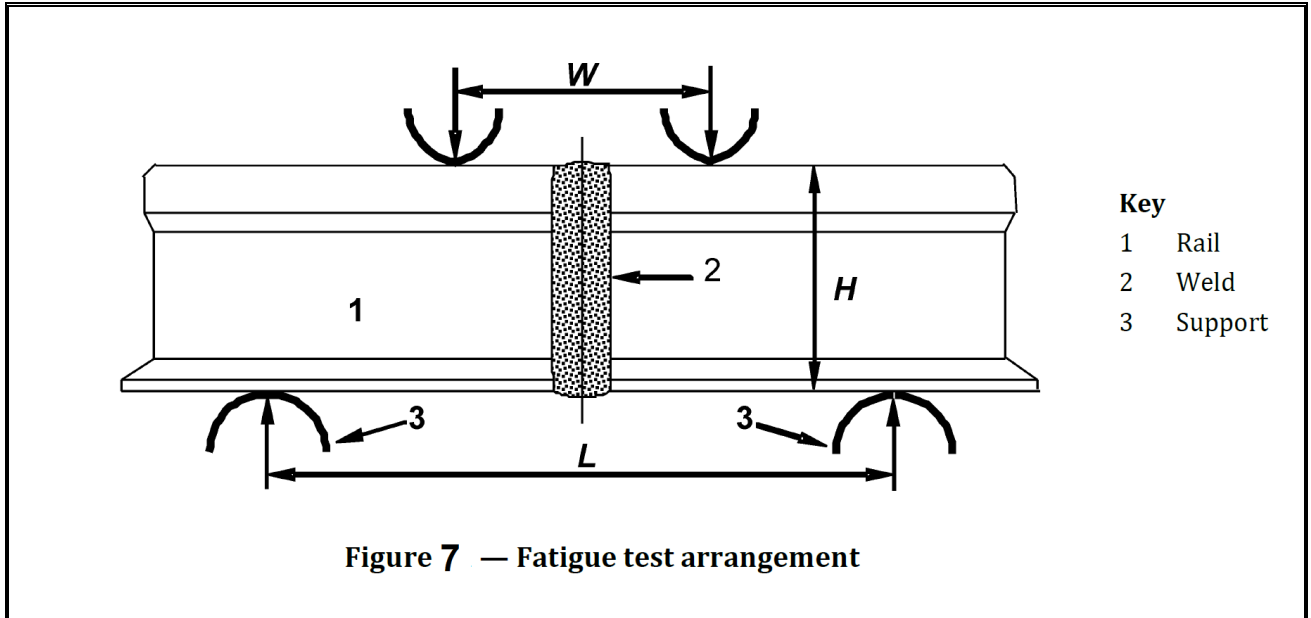

The inner span (W) shall be a minimum 150 mm plus weld collar width under the foot. The outer span (L) shall exceed the inner span by at least twice the rail height (H) and shall be symmetrical about the inner span

$$L \geq W + 2*H$$

The inner and outer spans shall be measured and recorded. The distances from the centre line of the actuator to the loading points shall be measured and recorded. Corresponding dimensions on either side of the actuator centre line shall not differ by more than 3 mm.

The radius of curvature of the loading points shall not be less than 40 mm. The loading point contact surfaces shall be free to translate or rotate so that friction between the loading points and the specimen is minimized.

**ANNEXURE-5**

**Performa for Field Trial**

**General information of field trial joints for AT welding technique for..... grade rails with ----- mm gap, Compressed Air-Petrol pre-heating, three piece mould (Zircon washed) and Single Shot Crucible fitted with Automatic tapping thimble developed by M/s .....**

- 1.Name of welding supervisor and Competency details :
- 2.Name of welder and Competency details :
3. Portion's Batch no. :
4. Date of manufacture of portion :
5. Weight of portion :
6. Heating Technique :
7. Heating Device :
8. Type of Mould :
9. Welding done in situ/cess :
10. Tapping Time :
11. Chipping device and time :
12. Grinding done by :
13. Under Sr. Section Engineer :
14. Section :
15. Division :
16. GMT of the section :

**Sign of Firm's Representative**

**Sign of Nominated Railway official  
(Not below the rank of JE/SSE)**

**Counter sign of concerned sectional ADEN**

ALOK NATH GUPTA <small>Digitally signed by ALOK NATH GUPTA Date: 2022.02.05 12:44:26 +05'30'</small>	Jaina Ram Meena <small>Digitally signed by Jaina Ram Meena Date: 2022.02.05 12:22:07 +05'30'</small>	SACHIN VERMA <small>Digitally signed by SACHIN VERMA Date: 2022.02.06 18:01:44 +05'30'</small>	Printed: Page 54 of 63
Prepared By: SSE/Track	Checked By: DD/Track/W	Issued By: DST-5	

### Performa for Field Trial

Particulars of field trial joints for AT welding technique for ----- grade rails with ---- mm gap, Compressed Air-Petrol pre-heating, three piece mould (Zircon washed) and Single Shot Crucible fitted with Automatic tapping thimble developed by M/s.....in...Divn./ ..... Railway.

S.N.	Joint No.	Km/ post	Chainage	UP/Dn., RH /LH	Between Station	Date of Welding	In Situ/	Rail Gap (in mm)	Batch no.	Portion no.	Pre-heating Time (in Min.)	Tapping Time (in sec.)	Nature of Reaction	Mould waiting time (in Min.)	Tolerance in Weld		Remarks
															With 1m st. edge Ver: +1.0mm -0.0mm Lat: ±0.5mm	With 10 cm st. edge in head Top: +0.4mm - 0.0mm Gauge Side: ±0.3mm	

Sign of Firm’s Representative                      Sign of Nominated Railway official (Not below the rank of JE/SSE)                      Counter sign of concerned sectional ADEN

**ANNEXURE-5A**

**INITIAL USFD TEST REPORT OF FIELD TRIAL JOINTS FOR AT WELDING TECHNIQUE FOR  
 ..... DETAILS OF AT WELDING TECHNIQUE ..... DEVELOPED BY  
 M/s.....**

**Machine Details:-** (Make, Model no. and Sl.No.)

SL.	Section(Between Station)	Joint No.	Location KM/TP	Chainage	Line	UP/DN	LH/RH	Rail	Section	Ultrasonic Test Results For*					Remarks#
										0° PROBE/2MHZ	AT WELD HEAD scanning 70° PROBE/2MHZ	AT WELD FLANGE scanning 70° PROBE/2MHZ	AT WELD FOOT scanning 45° PROBE/2MHZ	TANDEM PROBE scanning 45° PROBE/2MHZ	
1		1													
2		2													
3		3													
4		4													
5		5													
6		6													
7		7													
8		8													
9		9													
10		10													
-		-													
50		50													

\*For each type of USFD testing if any flaw peak is observed, Details of peak height (in terms of Full scale height)/travel and location (as per Note given at Chapter 8 of USFD Manual) be given ,Write “OK” if satisfactory.  
 # Classification of AT weld as per USFD Manual be indicated Write “OK” if satisfactory.

**Signature of Operator**

**Counter signed with date and designation  
 (Not below DEN rank officer)**



**ANNEXURE-5B**

**FINAL USFD TEST REPORT OF FIELD TRIAL JOINTS FOR AT WELDING TECHNIQUE FOR .....  
 DETAILS OF AT WELDING TECHNIQUE..... DEVELOPED BY M/s.....**

**Machine Details:-** (Make, Model no. and Sl.No.)

SL.	Section(Between Station)	Joint No.	Location KM/TP	Chainage	Line	UP/DN	LH/RH	Rail	Section	Ultrasonic Test Results For*					Remarks#
										0° PROBE/2MHZ	AT WELD HEAD scanning 70° PROBE/2MHZ	AT WELD FLANGE scanning 70° PROBE/2MHZ	AT WELD FOOT scanning 45° PROBE/2MHZ	TANDEM PROBE scanning 45° PROBE/2MHZ	
1		1													
2		2													
3		3													
4		4													
5		5													
6		6													
7		7													
8		8													
9		9													
10		10													
-		-													
50		50													

\*For each type of USFD testing if any flaw peak is observed, Details of peak height (in terms of Full scale height)/travel and location (as per Note given at Chapter 8 of USFD Manual) be given ,Write “OK” if satisfactory.  
 # Classification of AT weld as per USFD Manual be indicated Write “OK” if satisfactory.

**Signature of Operator**

**Counter signed with date and designation  
 (Not below DEN rank officer)**

ALOK NATH GUPTA <small>Digitally signed by ALOK NATH GUPTA Date: 2022.02.05 13:44:26 +05'30'</small>	Jaina Ram Meena <small>digitally signed by jaina ram meena Date: 2022.02.05 13:20:57 +05'30'</small>	SACHIN VERMA <small>Digitally signed by SACHIN VERMA Date: 2022.02.06 18:01:44 +05'30'</small>	Printed:
Prepared By: SSE/Track	Checked By: DD/Track/W	Issued By: DST-5	Page 57 of 63

## ANNEXURE-5C

### Final Inspection Report of Field Trial Joints

**Final Inspection report of field trial joints for AT welding technique for.... rails with ----- mm gap, Compressed Air-Petrol pre-heating, three piece mould (Zircon washed) and Single Shot Crucible fitted with Automatic tapping thimble developed by M/s .....**

1. Name of welding supervisor and Competency details :
2. Name of welder and competency details :
3. Portion's Batch no. :
4. Date of manufacture of portion :
5. Weight of portion :
6. Heating Technique :
7. Heating Device :
8. Type of Mould :
9. Welding done in situ/cess :
10. Tapping Time :
11. Chipping device and time :
12. Grinding done by :
13. Under Sr. Section Engineer :
14. Section :
15. Division :
16. GMT of the section :

**Sign of Firm's Representative**

**Sign of Nominated Railway official (Not below the rank of JE/SSE)**

**Counter sign of concerned sectional ADEN**

ALOK NATH GUPTA <small>Digitally signed by ALOK NATH GUPTA Date: 2022.02.05 13:44:26 +05'30'</small>	Jaina Ram Meena <small>Digitally signed by Jaina Ram Meena Date: 2022.02.05 13:29:57 +05'30'</small>	SACHIN VERMA <small>Digitally signed by SACHIN VERMA Date: 2022.02.06 18:01:44 +05'30'</small>	Printed:
Prepared By: SSE/Track	Checked By: DD/Track/W	Issued By: DST-5	Page 58 of 63

### Final Inspection Report of Field Trial Joints

Final Inspection report of field trial joints for AT welding technique for ..... rails with ----- mm gap, Compressed Air-Petrol pre-heating, three piece mould (Zircon washed) and Single Shot Crucible fitted with Automatic tapping thimble developed by M/s .....

SN	Joint No.	Km/ post	Chainage	UP/ DN	LH/RH	Between Station	Date of Welding	In Situ/ Cess	Date of Laying	USFD Result	Tolerance in Weld		Physical condition	Remarks
											With 1m st. edge Ver: +1.0mm -0.0mm Lat: ±0.5mm	With 10 cm st. edge Top: +0.4mm -0.0mm Lat: ±0.3mm		

Sign of Firm’s Representative

Sign of Nominated Railway official (Not below the rank of JE/SSE)

Counter sign of concerned sectional ADEN

<p>ALOK NATH GUPTA <small>Digitally signed by ALOK NATH GUPTA Date: 2022.02.05 12:44:26 +05'30'</small></p>	<p>Jaina Ram Meena <small>digitally signed by jaina ram meena Date: 2022.02.05 13:29:17 +05'30'</small></p>	<p>SACHIN VERMA <small>Digitally signed by SACHIN VERMA Date: 2022.02.06 18:01:44 +05'30'</small></p>	<p>Printed: Page 59 of 63</p>
<p>Prepared By: SSE/Track</p>	<p>Checked By: DD/Track/W</p>	<p>Issued By: DST-5</p>	

**APPENDIX- I**

**REQUIREMENTS FOR SODIUM SILICATE**

Extracts from **IS: 6773-1978** (Reaffirmed -2003)

**Cl.4.2** The material shall conform to requirements given in Table below:  
(For appropriate grade to be decided by the manufacturer)

S.No.	Characteristic	Requirement	Method of Test (Ref to Clause No. in Appendix A of IS:6773-1978)
i)	Total soluble silica (as SiO <sub>2</sub> ), percent by mass		A-3 and A-5
ii)	Total alkalinity (as Na <sub>2</sub> O), percent by mass		A-4 and A-5
iii)	Mass ratio of total soluble silica (as SiO <sub>2</sub> ) to total alkalinity (as Na <sub>2</sub> O)		A-6
iv)	Relative density at 20 <sup>0</sup> C		--
v)	Total invert sugar contents, percent		A-7

**Cl. 7.1(c)** Date of manufacture and date of expiry, if any.

**APPENDIX-II**

**REQUIREMENTS FOR ALCOHOL BASE ZIRCON WASH**

Extracts from **IS: 10033-1992** (Reaffirmed-2003)

**Cl.5 Condition of the material:**

The material shall be of uniform nature free from lumps whether in powder paste or in ready to use form.

**Cl.6.1 Chemical composition of Zircon-wash Gr-ZA:**

When tested in accordance with IS: 10085-1982, the ZrO<sub>2</sub> content of ZA grade wash shall not be less than 60 percent.

**Cl.7.3 Coating Quality:**

Wash when prepared and applied as per the recommendation of supplier shall be of the following quality:

- a) The wash shall give an uniform coating free of cracks before and after baking.
- b) The dried coating shall be hard enough so that by scratching with nail, the coating does not peel off or by gentle rubbing material is not transferred to the finger.
- c) Alcohol base coated surface after ignition shall be free from wet patches in the surface.

**Cl.11.1** The bags or the containers shall be marked with manufacturer's name, production batch No., date of manufacture and date of expiry.

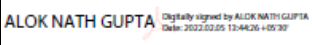
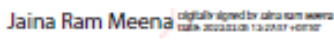
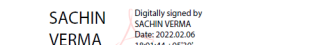
 <p><b>ALOK NATH GUPTA</b> Digitally signed by ALOK NATH GUPTA Date: 2022.02.05 13:46:26 +05'30'</p>	 <p><b>Jaina Ram Meena</b> Digitally signed by Jaina Ram Meena Date: 2022.02.05 13:29:57 +05'30'</p>	 <p><b>SACHIN VERMA</b> Digitally signed by SACHIN VERMA Date: 2022.02.06 18:01:44 +05'30'</p>	<p>Printed: Page 61 of 63</p>
Prepared By: SSE/Track	Checked By: DD/Track/W	Issued By: DST-5	

**APPENDIX III**

**LOCATION OF  
APPROVED WELD PROFILE DESIGN/ DIMENSION**

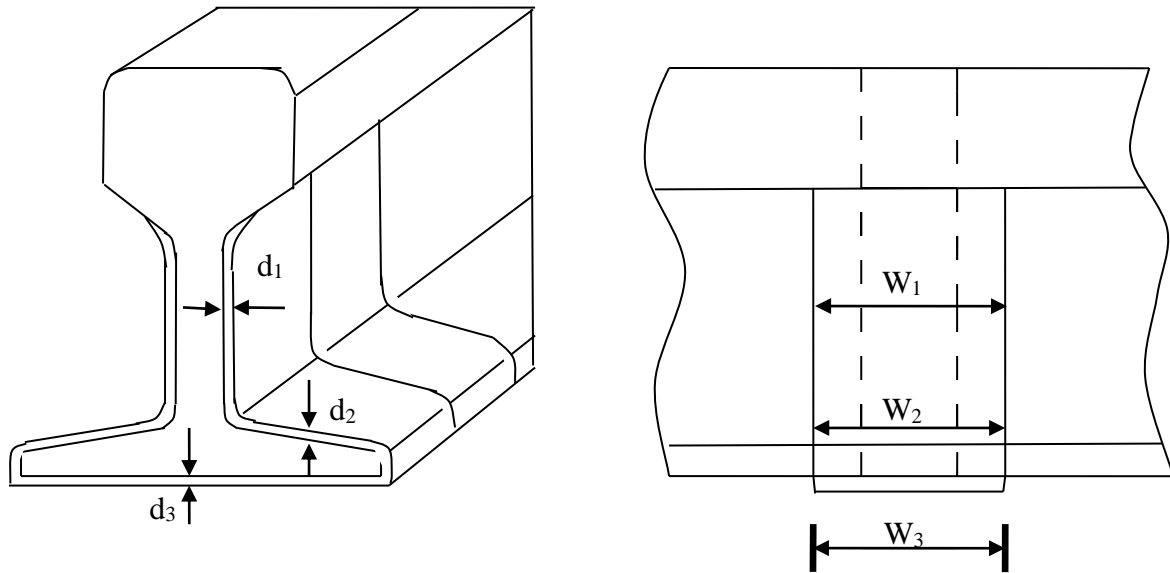

$W_1$  = Width at the centre of web at the location of  $d_1$  as shown in Fig.  
 $W_2$  = Width of reinforcement at foot at the location of  $d_2$  as shown in Fig.  
 $W_3$  = Width of reinforcement at bottom of flange at the location of  $d_3$  as shown in Fig.  
 $d_1$  = Thickness of reinforcement at web  
 $d_2$  = Thickness of reinforcement at foot  
 $d_3$  = Thickness of reinforcement at bottom of flange  
 All dimensions measured in mm.

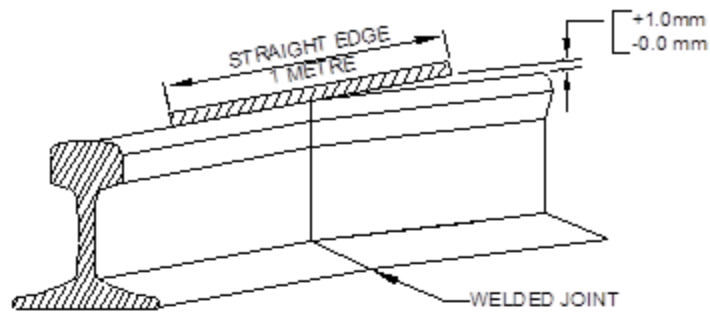

TOLERANCE FOR VERTICAL MISALIGNMENT OF WELDED JOINT

Fig. 8 (a)

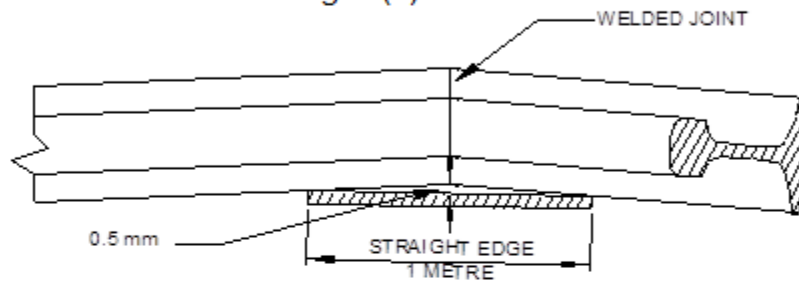

TOLERANCE FOR LATERAL MISALIGNMENT OF WELDED JOINT

Fig. 8 (b)

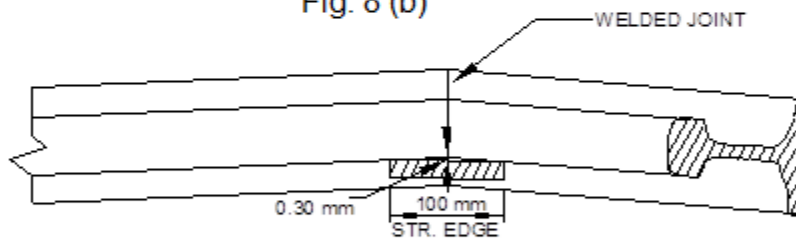

TOLERANCE FOR FINISHING ON SIDES OF HEAD OF WELDED JOINT

Fig. 8 (c)

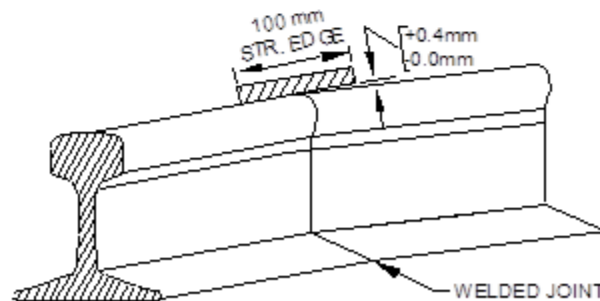

TOLERANCE FOR FINISHING TOP TABLE SURFACE OF WELDED JOINT

Fig. 8 (d)

<p><b>ALOK NATH GUPTA</b> Digitally signed by ALOK NATH GUPTA Date: 2022.02.05 13:44:26 +05'30'</p>	<p><b>Jaina Ram Meena</b> Digitally signed by Jaina Ram Meena Date: 2022.02.05 13:29:07 +05'30'</p>	<p><b>SACHIN VERMA</b> Digitally signed by SACHIN VERMA Date: 2022.02.06 18:01:44 +05'30'</p>	<p>Printed:</p>
<p>Prepared By: SSE/Track</p>	<p>Checked By: DD/Track/W</p>	<p>Issued By: DST-5</p>	<p>Page 63 of 63</p>